

# DESIGN REQUIREMENTS

May 29, 2024



## UNIVERSITY OF UTAH SUPPLEMENT

Reviewed: June 18, 2025

This document accepts the *DFCM Design Requirements* as the University's own, and supplements it with additional requirements shown in red text. These documents together form the core standard for architectural and engineering services provided on University projects.

<b>1.0</b>	<b>GENERAL</b> .....	<b>4</b>
1.1	GENERAL.....	4
1.2	PROCEDURE.....	4
1.3	HIERARCHY OF REQUIREMENTS .....	4
1.4	CHANGES AND ADDITIONS TO DESIGN REQUIREMENTS .....	5
1.5	UNIVERSITY APPROVED EQUAL.....	5
<b>2.0</b>	<b>CODES LAWS RULES AND REGULATORY REQUIREMENTS</b> .....	<b>7</b>
2.1	GENERAL.....	7
2.2	DFCM REQUIREMENTS INCLUDE (BUT ARE NOT LIMITED TO):.....	7
2.3	BUILDING CODE COMMISSION .....	7
2.4	FIRE PREVENTION BOARD.....	7
2.5	ACCESSIBILITY CODE .....	7
2.6	LABOR COMMISSION .....	7
2.7	DEPARTMENT OF HEALTH.....	8
2.8	DEPARTMENT OF ENVIRONMENTAL QUALITY .....	8
2.9	COUNTY HEALTH DEPARTMENT (FOR THE COUNTY WHERE THE FACILITY IS LOCATED).....	8
2.10	DEPARTMENT OF COMMERCE .....	8
<b>3.0</b>	<b>DFCM REQUIREMENTS</b> .....	<b>9</b>
3.1	GENERAL.....	9
3.2	CIVIL .....	17
3.#	GEOTECHNICAL.....	20
3.3	ARCHITECTURAL .....	22
3.4	STRUCTURAL.....	44
3.5	ELECTRICAL.....	45
3.6	MECHANICAL - GENERAL.....	51
3.7	PLUMBING.....	61
3.8	HVAC SYSTEMS .....	70
3.9	AUTOMATIC SPRINKLER SYSTEMS.....	78
3.10	COMPONENTS.....	79
<b>4.0</b>	<b>LANDSCAPE AND IRRIGATION STANDARDS</b> .....	<b>83</b>
4.1	GENERAL.....	83
4.2	WATER ALLOWANCE .....	84
4.3	LANDSCAPE DESIGN STANDARDS .....	84
4.4	IRRIGATION DESIGN STANDARDS .....	87
<b>5.0</b>	<b>STATE OF UTAH HIGH-PERFORMANCE BUILDING STANDARD (HPBS)</b> .....	<b>89</b>
5.1	INTEGRATED DESIGN PROCESS .....	91
5.2	COMMUNITY-ORIENTED DESIGN.....	93
5.3	TRANSPORTATION MANAGEMENT.....	94
5.4	SITE DESIGN.....	95
5.5	BUILDING PERFORMANCE .....	97
5.6	MATERIAL IMPACT REDUCTION.....	118
5.7	OCCUPANT WELLNESS .....	120
5.8	EDUCATION AND OUTREACH.....	122
5.9	ADDITIONAL RESOURCES .....	123
5.10	REFERENCES.....	123

**UofU Appendixes**

- Appendix A – List of University Approved Products
- Appendix B – Laboratory Design Requirements
- Appendix C – Security System Standards
- Appendix D – Outdoor Lighting System Standards
- Appendix E – Campus Utility Design Standards
- Appendix F – Site, Landscape, and Irrigation Design Standards

Appendix G – Tree Protection and Preservation Policy  
Appendix H – LEED Credits Quick Reference Guide  
Appendix I – UIT Design Standards Supplement

## 1.0 GENERAL

### 1.1 General

- A. These Design Requirements apply to all plans, processes, and procedures required for compliance
- B. The roles and responsibilities of the Director as outlined in this document may also be performed by the Director's designee.
- C. The Architect and/or Engineer (herein after referred to as "A/E") is to adhere to both the DFCM and University Design Requirements on all projects for the University whether the contract originates from DFCM or from the University of Utah.

### 1.2 Procedure

- A. Complete the Design Requirement/Variance Form to make recommendations for additions, deletions, and changes to the Design Requirements.
- B. Complete the Design Requirement/Variance Form to request approval by the Director to vary from these Design Requirements based upon the specific project needs.
- C. All Design Requirement modifications require approval by the Director. If the Design Requirement is approved by the Director, then the DFCM's Designated Representative shall distribute the Design Requirements Procedure document to the appropriate project participants and shall file it in the project file.
  - 1. If the Design Requirement is approved by the Director and has general applicability to other projects, then the Director shall request that the proposed modifications be considered by the Utah State Building Board.
    - a. Verify with the DFCM person responsible for the specific professional discipline and the appropriate DFCM maintenance person that the proposed Design Requirement meets their requirements.
- D. Complete the 'University of Utah Design Standards Change Request Form' to make recommendations for additions, deletions and changes to the University Design Requirements. All modifications shall require approval by the University's Design Standards Committee.
- E. Complete the 'University of Utah Design Standards Project Variance Request Form' for approval to vary from these Design Requirements based upon specific project needs. The A/E shall document why the current design requirement cannot be met, including valid justifications and recommended solutions. All variance requests require approval by the University's Design Standards Committee.

### 1.3 Hierarchy of Requirements

- A. The hierarchy of requirements is as follows:
  - 1. Comply with the minimum requirements of all applicable laws, rules, and regulatory requirements.
    - a. Exceptions: Wherever there are practical difficulties involved in carrying out these provisions, the State Building Official with the approval of the Director of DFCM and/or the State Fire Marshall shall have authority to grant modifications. The modifications granted by the State Building Official shall be documented in this standard under the heading "Design Requirements."
  - 2. Comply with the consensus-based ANSI standards for design, products, installation, and services unless the applicable laws, rules, and regulatory requirements are more stringent.
  - 3. Comply with the "Performance Requirements: Design Requirements" unless the ANSI standards or the applicable laws, rules, and regulatory requirements are more stringent.
  - 4. Comply with the Contract Documents, unless the "Performance Requirements: Design Requirements", the ANSI standards, or the applicable laws, rules, and regulatory requirements are more stringent.

- B. For DFCM managed projects, the State Building Official with the approval of the Director of DFCM and/or the State Fire Marshal shall have authority to grant modifications. DFCM modifications granted by the State Building Official shall be documented as required by DFCM.
- C. For University managed projects, the University Building Official and/or the University Fire Marshal shall have the authority to grant modifications. Any modifications granted by the University shall be documented as required by 1.4 below.

#### **1.4 Changes and Additions to Design Requirements**

- A. Complete the following document and submit it to the person to whom you are responsible to for ultimate decision by the Director, for requested changes/additions to the Design Requirements.

#### **1.5 University Approved Equal**

- A. The materials, products, and equipment described in the University Design Requirements establish the standard of required function, dimension, appearance, durability, warrantee, maintainability and quality to be met by any proposed alternative. The A/E may submit an approved equal product for consideration through the University Project Manager if they believe that a product meets or exceeds the current University Design Requirements. Refer to attached **Appendix A - University Approved Products**, see the "Procurement Requirement" column regarding proposed alternatives.
- B. The Design Professional shall submit proposed approved equal products to the University Project Manager for review and approval by the Design Standards Committee as a Project Variance Request prior to final inclusion in contract documents. The approved equal submittal shall include an analysis and recommendation by the design professional.

Project Name \_\_\_\_\_  
DFCM Project Number \_\_\_\_\_  
Agency \_\_\_\_\_

Date \_\_\_\_\_  
Risk ID # \_\_\_\_\_  
Requestor \_\_\_\_\_

Brief Description of the Request Variance

Design Requirements

Justification for the Request and Proposed Resolution if the Request is Accepted

Cost Impact: Describe the Short-term and Long-term Impact of the Request

Professional Reviewer \_\_\_\_\_  
Agency FM Approval \_\_\_\_\_  
PM Approval \_\_\_\_\_

Position \_\_\_\_\_  
Position \_\_\_\_\_  
Date \_\_\_\_\_

Director's Approval \_\_\_\_\_

Date \_\_\_\_\_

## 2.0 CODES LAWS RULES AND REGULATORY REQUIREMENTS

### 2.1 General

- A. Comply with adopted State Codes and all other applicable Standards and Codes at the time submitted to the State Building Official, including but not limited to Section 0 through Section 0.

### 2.2 DFCM requirements include (but are not limited to):

- A. Administrative Services: Comply with Title R23: Administrative Services, Facilities Construction and Management. Refer to [rules.utah.gov/publicat/code/r023/r023.htm](https://rules.utah.gov/publicat/code/r023/r023.htm)
- B. DFCM Services: Comply with Services requirements. Refer to [dfcm.utah.gov/](https://dfcm.utah.gov/) . Services requirements include:
  - 1. Inspections and Testing, refer to [dfcm.utah.gov/building-official/](https://dfcm.utah.gov/building-official/)
  - 2. Standards and Standard Project Documents, refer to [dfcm.utah.gov/dfcm-standard-documents/](https://dfcm.utah.gov/dfcm-standard-documents/)
  - 3. Roofing, Paving, and Hazardous Materials, refer to [dfcm.utah.gov/construction-management/](https://dfcm.utah.gov/construction-management/)
  - 4. Other requirements which may be added after this document is published.

### 2.3 Building Code Commission

- A. Comply with Utah State Construction and Fire Codes Act. Refer to Utah Code Title 15A. Enforcement of these codes is the responsibility of the State Building Official.
- B. On University of Utah projects, enforcement is the responsibility of the University's Building Official for University managed projects.

### 2.4 Fire Prevention Board

- A. Comply with Fire Codes in accordance with "Laws, Rules" of the State Fire Marshal. Refer to [firemarshal.utah.gov](https://firemarshal.utah.gov). Enforcement of these codes is the responsibility of the Utah Fire Marshal.
- B. The A/E is to coordinate with the University Fire Marshal. University Fire Marshal to provide a list of meetings with key personnel to attend, including University Project Manager and DFCM Project Manager (as applicable).
- C. Hot Works Policy and Training shall be in compliance with DFCM requirements and coordinated with University Fire Marshal.

### 2.5 Accessibility Code

- A. Comply with the US Department of Justice Federal Registers – Americans with Disabilities Act. Refer to [ada.gov/](https://ada.gov/)

### 2.6 Labor Commission

- A. Comply with requirements of the Labor Commission. Refer to [laborcommission.utah.gov/](https://laborcommission.utah.gov/)
  - 1. Boiler and Pressure Vessel Compliance Manual, Refer to [laborcommision.utah.gov/wp-content/uploads/2019/11/Boiler-Compliance-Manual-2.pdf](https://laborcommision.utah.gov/wp-content/uploads/2019/11/Boiler-Compliance-Manual-2.pdf)
  - 2. Utah Occupational Safety and Health, refer to [rules.utah.gov/publicat/code/r614/r614-001.htm](https://rules.utah.gov/publicat/code/r614/r614-001.htm)

3. Elevator Rules: American National Standard Safety Code for Elevators and Escalators, ANSI/ASME A17.1 with amendments administered by Labor-Industrial Commission of Utah, Department of Occupational Safety and Health Elevator Division. Refer to [rules.utah.gov/publicat/code/r616/r616-003.htm](http://rules.utah.gov/publicat/code/r616/r616-003.htm)

## 2.7 Department of Health

- A. Comply with requirements of Department of Health. Refer to [dhhs.utah.gov/](http://dhhs.utah.gov/)
  1. Health Care Rules, refer to [dlbc.utah.gov/home/office-of-licensing/health-facilities/rules-and-descriptions/](http://dlbc.utah.gov/home/office-of-licensing/health-facilities/rules-and-descriptions/)
  2. Utah Indoor Clean Air Act, refer to [rules.utah.gov/publicat/code/r392/r392-510.htm](http://rules.utah.gov/publicat/code/r392/r392-510.htm).

## 2.8 Department of Environmental Quality

- A. Comply with requirements of Department of Environmental Quality. Refer to [deq.utah.gov/](http://deq.utah.gov/).
  1. Public Drinking Water Rules, refer to [deq.utah.gov/division-drinking-water](http://deq.utah.gov/division-drinking-water)
  2. Utah Division of Air Quality: R307-801, Asbestos, refer to [rules.utah.gov/publicat/code/r307/r307.htm](http://rules.utah.gov/publicat/code/r307/r307.htm)  
Environmental Protection Agency (EPA): Regulations for Asbestos – Code of Federal Regulations Title 40, Part 61 Subpart M; and Toxic Substances Control Act PART 763 (Updated 1997) – ASBESTOS: OSHA Standards 1910.1001, 1915.1001, and 1926.1101
  3. Underground Storage Tank Act, refer to [deq.utah.gov/underground-storage-tanks](http://deq.utah.gov/underground-storage-tanks)
  4. Air Conservation Act, refer to [le.utah.gov/xcode/Title19/Chapter2/19-2](http://le.utah.gov/xcode/Title19/Chapter2/19-2)
  5. Fugitive Dust Plan, Refer to [rules.utah.gov/publicat/code/r307/r307-309.htm](http://rules.utah.gov/publicat/code/r307/r307-309.htm)
  6. Utah Pollutant Discharge Elimination System, Refer to [rules.utah.gov/publicat/code/r317/r317.htm](http://rules.utah.gov/publicat/code/r317/r317.htm)
  7. Operating Permits of the Division of Air Quality, refer to [rules.utah.gov/publicat/code/r307/r307-415.htm](http://rules.utah.gov/publicat/code/r307/r307-415.htm)
  8. For all new buildings larger than 10,000 gross square feet and renovations to existing buildings affecting more than 10,000 gross square feet that are subject to an Air Emissions permit or the State Implementation Plan (SIP), consultant shall determine the total annual natural gas consumption for the project and submit that to DFCM and the state entity associated with the project at least 90 days prior to completion of contract documents so that compliance can be confirmed with Air Emissions permits and the SIP. Failure to do so will jeopardize approval for the startup and operation of any new natural gas equipment or increases in output of existing natural gas fired equipment.

- B. In addition to the DFCM requirements, the A/E shall coordinate with the University's Environmental Health & Safety Office for specific University requirements (e.g. MS4 Stormwater Permit).**

## 2.9 County Health Department (for the county where the facility is located)

- A. Food Service Sanitation Rules

## 2.10 Department of Commerce

- A. Pipeline Safety, refer [rules.utah.gov/publicat/code/r746/r746-409.htm](http://rules.utah.gov/publicat/code/r746/r746-409.htm)
- B. Qualifications: Refer to the Project Participants heading of this document.

### 3.0 DFCM REQUIREMENTS

These requirements are enhancements of code requirements that DFCM has initiated for best practices for State owned facilities.

#### 3.1 General

##### A. Enhanced Accessibility

1. “It is the policy of the Utah State Building Board that, when appropriate for the intended use of the building and achievable within the project budget, the following accessibility enhancements beyond those required by the Americans with Disabilities Act be provided for in state owned buildings and buildings leased by DFCM: (1) powered door openers for the primary entrance designated for use by people with disabilities, and (2) powered door openers for one uni-sex restroom or for one male and one female restroom in the building unless restrooms with a door-less entry are provided. This policy is not intended to limit the use of powered door openers to the standard set forth herein. This policy applies to the construction or major renovation of state-owned facilities and new leases where the entire building is being leased by DFCM. This policy is not intended to create any rights to any third parties.
2. Determinations that this enhancement is not appropriate for the intended use of the building or not possible within the project or lease budget shall be made by the Director or his designee. Determinations of whether this enhancement to accessibility is appropriate should consider the potential of access by people with disabilities. The Director may determine that powered door openers are appropriate for the primary entrance while not warranted or not possible within the budget for access to restrooms. The Director may also determine that one or both of these enhancements are not feasible in (a) the renovation of an existing building due to its design or configuration or (b) in a leased facility due to the nature and circumstances of the lease.”
3. University of Utah projects managed either by DFCM or the University of Utah shall include in the project's scope of work the construction of primary or secondary accessible paths of travel, or improvements to existing primary/secondary accessible paths of travel. The intent of this requirement is to enhance and provide consistency with the network of accessible pathways throughout the University campus or University owned properties. This requirement shall apply to new buildings, additions to existing buildings, site landscaping, civil or utility infrastructure improvements which interface with or impact the primary and secondary accessible routes as shown in the Accessible Paths of Travel Study. The University Project Manager or Project Planner shall determine the extent of this requirement during the planning or programming phase. During the feasibility and/or programming phase, the A/E shall provide design solutions as guided by the Accessible Paths of Travel Study a copy of this Study will be provided by the University Project Manager or Planner.

##### B. Energy Efficient Products

1. Select, where life-cycle cost-effective, products in the upper 25 percent range of the energy efficiency rating. Energy efficient products include:
  - a. Heating and cooling equipment;
  - b. Motors;
  - c. Lighting fixtures, compact fluorescent light bulbs, exit signs;
  - d. Windows, doors and skylights;
  - e. Roof products;
  - f. Food service equipment;
  - g. Transformers;
  - h. Office equipment;
  - i. Electronics; and
  - j. Appliances.
2. Exceptions

- a. Energy-efficient products that have been stipulated as life-cycle cost-effective by DFCM.
  - b. ENERGY STAR® products that are certified and labeled through the US Environmental Protection Agency.
  - c. Energy Efficient Products listed items on General Service Administration, GSA Advantage website. “Energy Efficient Products” mean items that meet Federal Energy Management Program (FEMP) energy efficiency levels as required by the Federal Acquisition Regulation (FAR) Subpart 23.203, Executive Order 13123, and Executive Order 13221.
3. When remodeling any building, the energy efficiency and operating characteristics of existing and new equipment shall not be diminished by the building revisions.

**C. Energy Design Standards: See Section 5.0 High-Performance Building System**

1. The DFCM High Performance Building Systems (HPBS) apply to all University design and construction projects.

**D. Hazardous Materials**

1. DFCM shall procure a qualified abatement consultant during the Schematic Design phase of the Design stage. The abatement consultant shall survey all renovation and demolition projects for hazardous materials such as asbestos-containing building materials, lead-based paint, mold, universal wastes such as PCBs, CFCs, mercury, household/janitorial cleaning products, identified/unidentified containers of chemicals or products, or any other materials or waste that may be environmentally unsafe.
2. Prior to the start of a survey by the abatement consultant, the A/E shall provide drawings at the design development phase of the design stage to the abatement consultant with sufficient information to define the building or facility areas affected by the renovation or demolition. The abatement consultant shall coordinate abatement documents with the updated Contract Documents prior to final preparation. The abatement consultant shall prepare a complying and comprehensive hazardous materials survey report identifying and quantifying all hazardous and non-hazardous building materials to include asbestos-containing building materials, lead-based paint, mold and universal wastes that affect the areas of renovation or demolition.
3. DFCM shall procure a qualified abatement contractor to remove all hazardous materials prior to the beginning of any building demolition or renovation.
4. A/E shall coordinate with University Project Manager regarding hazardous materials on site, including both building materials and stored materials.

**E. Vibration**

1. Design structure in accordance with the following minimum requirements for vibration:

Space Category	Vibration Sensitivity
Laboratories with equipment sensitive to vibration	Comply with manufacturer’s requirements for vibration.
Offices, classrooms, and other similar spaces.	There are no vibrations from machines or traffic which are detectable by people.
Common Area spaces.	There is occasional movement in the floor when heavy equipment are moved nearby.
Storage spaces.	There is obvious and annoying movement when people walk by or equipment is being moved nearby.

**F. Utah Space Standards**

1. Comply with the “Utah Space Standards,” August 1994. Refer to [dfcm.utah.gov/wp-content/uploads/State-of-Utah-Office-Standards\\_2016.02.26.pdf](http://dfcm.utah.gov/wp-content/uploads/State-of-Utah-Office-Standards_2016.02.26.pdf)

#### G. Infrastructure Flexibility

1. Interior Shear Walls: Minimize interior shear walls, bearing walls and braced frames which may disrupt future additions or modifications to the facility.
2. Spare Mechanical Space: Provide 25% spare space in pipe chases and for mechanical equipment (except air handlers).

Main Electrical Room: Locate main electrical room close to transformer and near the center of the load (which is usually located near where central mechanical equipment is located). Locate panel boards in satellite electrical rooms dedicated for electrical equipment and which stack vertically in the facility.

3. Spare Electrical Capacity: Provide 25% future space for additional overcurrent protection devices in panel boards and switchboards. Provide 25% additional load capacity in addition to the capacity required for continuous loads in panel boards and switchboards.
4. Communication Rooms: Locate communications rooms so they stack vertically and comply with TIA/EIA standards.
5. Spare Communication System Capacities: Provide 100% future space (this is not necessarily horizontal space, but may be vertical space in racks for future equipment) for cabling, data, and communications electronic equipment.
6. Equipment Access: In new facilities, provide access for replacement of equipment which does not require demolition.
7. Storage Space: Provide a minimum 6’ X 6’ space for storage of janitorial supplies or .2% of the gross square footage, whichever is greater.

#### H. Standard Building Plaque

1. For development projects provide a design for a building plaque to be mounted on a prominent wall near the entrance to the building in compliance with the DFCM plaque standard. Refer to [dfcm.utah.gov/wp-content/uploads/plaque\\_policy.pdf](http://dfcm.utah.gov/wp-content/uploads/plaque_policy.pdf)
2. A/E shall coordinate with University Project Manager for specific University design.

#### I. Construction Coordination

##### (1) Work Restrictions

- a. The A/E is to work with Facilities Management through the University Project Manager to establish the limits of construction during the design development stage to include the area which is affected by the work. If possible, this is to include areas affected by the shutdown of the landscape irrigation.

##### (2) Utility Locate Request

- a. Where information is needed on existing utilities, including irrigation, use the University of Utah Utility Locate Request Form. Refer to <https://facilities.utah.edu/utility-locate-request/>.

##### (3) Traffic Management Plan

- a. Traffic control is a major concern on campus. Consult with Facilities Management through the University Project Manager to identify procedures to be used in a traffic management plan for the project. Describe access routes to the job site through the campus for concrete trucks, delivery trucks and other vehicles concerned with the project. The approved plan should be detailed for the Contractor and included as part of the project documents.

##### (4) Construction Impacts to Existing Utilities, Services, and Operations

- a. Where existing utilities, services, and/or operations are impacted by construction, Contractor shall coordinate with University Project Manager to submit impacts to FMRC (Facilities Management Review Committee) for review and approval. Impacts requiring shut-downs (or the potential for a shut-down) shall include

- PACE (Primary, Alternate, Contingency, & Emergency Plan) plan to address mitigation during construction and assure continued operation. Work shall not proceed without FMRC approval.
- (5) Parking Requirements for Construction
- a. Project Parking Plan shall be developed to establish the parking impact during and after a construction Project. This Plan is to be done during the design process to provide direction in the contract documents that will inform the bidding and successful contractor what parking will be available to the project during construction. This plan is to be developed jointly by the Design Team, University Project Manager, University Project Planner, and University Commuter Services. Once prepared, the Parking Plan form is to be included with the design documents when they are submitted for plan review, preferably at DD review, but no later than CD. The Plan shall be approved during the plan review process and the information then included in the bid contract documents.
- (6) Contractor's Use of Building Equipment
- a. Include provisions for the Contractor to use equipment such as electric motors, blowers, heat exchangers, filters, lighting fixtures, etc., with the written permission of the University. As each piece of equipment is used (such as electric motors and blowers), require the Contractor to follow maintenance procedures approved by the manufacturer. Require the Contractor to maintain a careful record of the time used, maintenance procedures followed, and any difficulties experienced with the equipment. These contractors' records on the equipment are to be submitted to the University upon acceptance.
- b. For extended projects, require the Contractor to replace used expendables of the equipment with new replacements which meet equipment and project specifications (i.e., belts, filter media, fluorescent lamps, bearings, etc.). Require these items to be inspected just prior to acceptance. Any excessive wear noted during the inspection shall require replacement. Require the guarantee period for equipment to begin with Substantial Completion acceptance by the University. Coordinate these items with Facilities Management (especially Facility Operations) through the University Project Manager.
- (7) Temporary Facilities for Construction
- a. Include provisions for a construction area fence and gate at least 6-ft high. Refer to 4.3 F for chain link fence requirements. Where safety area fences are also providing protection from falls, fences shall meet all applicable OSHA fall protection requirements.
- b. Require the Contractor to provide dust and noise barriers in all remodeling areas.
- c. Temporary Project Sign requirements should be coordinated with the University Project Manager.
- d. Where construction sites interrupt existing pedestrian pathways (determined by consultation with Facilities Management, and the Environmental Health & Safety officials through the University Project Manager), such pathways shall be replaced with temporary walks to circumvent the interrupted areas. Damage to existing walkways shall be restored at the completion of construction at Contractor's expense whether inside or outside (adjacent to) the construction site.
- e. The A/E is to specify and delineate requirements for the Contractor to provide adequate outdoor lighting along walkways and around the perimeter of construction site. Such lighting shall be operational for all hours of darkness during extent of construction.

#### J. Emergency Phones

- (1) The decision to install emergency phones as part of a construction project will be by the University. The University Project Manager will obtain University approval to include E-phones in the project design; and, obtain approved equipment specifications through the Managing Director of Environmental Health & Safety and Emergency Management, and

- the University Chief of Police.
- (2) Facilities management, through the University Project Manager, will provide to the A/E:
- a. Guide specifications for approved emergency phone devices.
  - b. Specific E-phone functionality and operational characteristics required by University Public Safety.
  - c. For Housing, Main Campus, and Parking Lot elevators, the “call” button shall be directed to Dispatch. For other properties, confirm “call” button recipients with the University Project Manager.
  - d. Contractor instructions for equipment connections.

**K. Demolition – Expectations of the A/E’s Design**

- (1) Prior to Design Development Submittal
- a. During the design of the project (before submission of the design development documents for review), the A/E, together with its sub consultants, shall identify furnishings, accessories, equipment, material, systems, etc. which will be affected or removed by demolition.
  - b. The A/E and sub consultants as appropriate shall meet with the University Project Manager, representatives from Facility Operations, and a representative of University Surplus and Salvage. This focus of this meeting will be to determine final ownership of all of removed items; and, for those items returned to the University, any required preparation, delivery and transfer instructions.
    - i. Items which will remain the property of the University shall be clearly identified and listed for inclusion in the Contract Documents.
      - (a) Generally, all fire alarm components will remain the property of the University. The disposition of removed fire alarm wiring and conduit will be considered on a project by project basis.
    - ii. Include instructions to the Contractor for preparations and delivery of each of the removed items to the University (safety preparations, coiling, packaging, palletizing, cleaning, prior notification, delivery location, etc.).
  - c. The A/E may be asked to tag or otherwise identify specific items at the site before demolition to aid the Contractor’s awareness and protection of University property.
  - d. Remaining items which will become the property of the Contractor shall be included in the Contract Documents, allowing the Contractor to include salvage value in the bid. This may be a general summarization of all remaining demolition, or specific items or systems.
    - i. Include both declarations in the design development review documents as they are intended to appear in the bidding documents.
    - ii. Include salvage value in the detailed cost estimate.
- (2) Site Visit Reports
- a. Include the disposition of items which are identified to be returned to the University in site visit reports.

**L. Parking and Service Access**

- (1) Provide service area for a minimum of two trucks adjacent to each building and provide space for trash containers which will be picked up by a truck lift.
- (2) The University uses the dumpster system of trash removal. This consists of metal containers placed outside each building (one per building is usually required) in which the trash is deposited.
- (3) All dumpsters are to be enclosed in an appropriate enclosure and screening device appropriately located on the site. The design for the approach to the enclosure shall be reviewed with Facilities Management prior to going to bid.

**M. University Hospitals, Clinics and the School of Medicine – Special Design Requirements**

- (4) University of Utah Health Care (UUHC) operates University hospitals, clinics, and other

- facilities throughout the State.
- (5) UUHC Department of Facilities & Engineering (Hospital F&E) manages some projects under delegation from U of U Facilities Management.
- (6) All requirements described in the DFCM Design Manual and University of Utah Supplement (Programming Standards, Design Process, and Design Requirements) apply to all UUHC projects. The UUHC Hospital Design Standards and the UUHC Contractor Handbook supplement, but do not replace A/E requirements for design described in the DFCM Design Manual and University of Utah Supplement.
- (7) UUHC Hospital Design Standards
- a. Special design requirements for UUHC projects are described herein below and in the UUHC Hospital Design Standards. The UUHC document is available from Hospital F&E through the University Project Manager. UUHC standards may be applicable to the Project for hospital grade materials and finishes, and/or non-patient care construction requirements. Where UUHC Hospital Design Standards are silent on any design issue, the instructions provided in the DFCM Design Manual and this Supplement shall apply.
- (8) UUHC Contractor Handbook
- a. Special construction requirements for UUHC projects are described in the Contractor Handbook for UUHC Construction Projects (or “Handbook”) available on the University’s Facilities Management web site. The Handbook shall be included in the A/E’s project specifications, either in print or by reference. The A/E’s specifications shall require the Contractor to print the Handbook for use during construction.
- b. Parking and staging areas
- i. The A/E shall coordinate with the FM Project Manager / Hospital F&E Project Supervisor to determine appropriate staging and parking areas for the Project, and include this information in the Project design drawings or specifications.
- ii. Include a warning that emergency access to UUHC facilities, and patient, staff, fire lane, and handicapped parking is critically important to UUHC operations, and must not be impeded, even temporarily.
- c. Stair / Elevator Access
- i. The A/E shall coordinate with the FM Project Manager / Hospital F&E Project Supervisor to identify appropriate routes for Contractor access to the work site, including selected stairwells and elevators for the transport of materials. This information shall be included in the Project design drawings or specifications and describe or show any areas to be avoided by construction workers.
- d. Special Working Hours
- i. The A/E shall coordinate with the FM Project Manager / Hospital F&E Project Supervisor to determine the need for special working hours, and certain hours when noise transmission must be limited. Any special requirements must be included in the Project design drawings or specifications.
- e. Restroom Limitations
- i. The A/E shall coordinate with the FM Project Manager / Hospital F&E Project Supervisor to determine the limitations to be imposed on the use of restrooms in the facility. Unless approved otherwise, the A/E shall specify that the Contractor shall provide hand washing and restroom facilities for its personnel, separate from UUHC restrooms.
- f. Dumpster Locations
- i. The A/E shall coordinate with the FM Project Manager / Hospital F&E Project Supervisor to determine approved locations for the Contractor’s dumpsters/trash receptacles, and show these on the Project drawings.
- g. Requirements for Interim Life Safety Measures (ILSM)

- i. The A/E shall coordinate with the FM Project Manager / Hospital F&E
- ii. Project Supervisor for a site review meeting held with the Hospital Fire Marshal, the infection control team, and any other applicable safety team to assess the proposed construction to identify any possible compromise to the building's life safety system.
- iii. The A/E shall keep accurate minutes of the meeting. Documents provided by UUHC life safety staff for use on the Project shall be combined with applicable items in the A/E minutes to form an "ILSM Project Plan." A specific form or format will be required by UUHC.
- iv. The ILSM Project Plan must include the Statement of Conditions fire drawings, including requirements for patching walls, available from the Hospital Fire Marshal or the Hospital F&E Project Supervisor. iv. Insert the ILSM Project Plan, the required ILSM Form, and all terms of the ILSM plan in the Project specifications, including but not limited to assessment summaries, expected UUHC monitoring, the maximum number of expected debrief meetings, any required documentation to be posted and/or kept in a Contractor's project file on site, any required Contractor reports with expected frequency, any other special procedures, etc.
- h. Requirements for Infection Control Construction Risk Assessment
  - i. An Infection Control Construction Risk Assessment (ICRA) is generally required on all projects affecting or near patient areas. UUHC will initiate the ICRA for each applicable project, and the A/E shall apply the project's completed ICRA to the drawings and specifications, and require the Contractor to comply with ICRA safety measures and requirements.
  - ii. Include any other project specific requirements directed by the UUHC's safety team or infection control team (e.g., assessment, documentation, monitoring, reports, special procedures, pressure / flow indicators, tacky mats, etc.).
- i. Dust, Vapor, Etc., Containment
  - i. The A/E shall coordinate with the FM Project Manager / Hospital F&E Project Supervisor to identify project requirements for the containment of dust, aerosol, fumes, vapors, etc. (e.g., any required approved plans, Contractor documentation, reports, etc.). Include any requirements in the Project specifications.
- j. Materials & Equipment Specified for UUHC Projects
  - i. All materials/equipment specified must be U/L approved. Require independent testing lab sheets with the Contractor's submittal.
  - ii. For all hospital and clinic designs, material and equipment components are required to be Hospital Grade. Coordinate with the FM Project Manager / Hospital F&E Project Supervisor to determine if Hospital certification will be required.
  - iii. Coordinate with the FM Project Manager / Hospital F&E Project Supervisor to identify approved finish materials for the Project specifications. This may include antimicrobial finish, which may be required for lab and medical doors.
  - iv. The design and resulting construction must meet federal/state/local and UUHC requirements.
  - v. Only non-asbestos containing materials may be specified.

**N. University of Utah Design Standards for Small Wireless Facilities**

- (9) The University of Utah Design Standards for Small Wireless Facilities dated August 29, 2018 is hereby incorporated into the University's Design Requirements. This document is available on the Planning, Design & Construction web site at: <https://pdc.utah.edu/aec/>

**O. See Appendix G Tree Protection and Preservation Policy**



### 3.2 Civil

#### A. Paving

1. Use untreated base course under all curbs and gutters. Use untreated base course material under all sidewalks exterior flatwork and paved areas.
2. Untreated base course under asphalt paving: Asphalt - 8” minimum compacted base (96%)
3. Concrete–curbs, gutters, sidewalks, exterior flatwork – Minimum 6” compacted base (96%) or minimum 4-3/4” crushed gravel.

Untreated Base Course	
Size	% by Weight Paving Sieve
1”	100
½”	70 to 100
#4	41 to 68
#16	21 to 41
#50	10 to 27
#200	4 to 13

4. Surface course (asphalt) aggregate:

Surface Course (asphalt)	
Size	% by Weight
½%	100
3/8”	70 to 100
#4	50 to 78
#16	30 to 48
#50	18 to 31
#200	7 to 13

5. Base course (lower lift) can be ¾” asphalt if placed in more than 1 lift.
6. Construct asphalt paving only when atmospheric temperature is above 50 degree F and underlying base is from moisture. Permit no vehicular traffic for at least 24 hours after laying asphalt pavements.
7. Striping paint: ~~State of Utah #780. Spread at the rate of 103–113 sf/gal. Minimum thickness shall be 7 dry mil.~~
  - a. For UofU paint, use UDOT Standard Specification – 02765 Pavement Marking – Waterborne Paint.
8. Tack coat all adjoining materials, i.e. previously constructed asphalt, concrete, etc. except untreated base course.
9. Surface smoothness: variation in the finished surface must not exceed 1/8” in 10 ft. in any direction.
10. Asphalt shall comply with Marshall Design with voids 1.5% to 3.0%
11. Performance Graded Asphalt Binder: Use PG58-28-DM-1/2
12. Drainage: Slope all asphalt concrete paving surfaces for positive drainage a minimum of 1.5% and preferable 2%.
13. Minimum thickness for parking areas: 3”. Minimum thickness for road areas and truck traffic is 3” including dumpster access.  
Maximum thickness for lifts: 3”
  - a. For UofU, minimum thickness for parking areas: 4”. Minimum thickness for road areas and truck traffic is 6” including dumpster access.
14. Sidewalk Requirements

- a. Sidewalks throughout campus are to be rated for heavy vehicle use. At a minimum, provide a 6-1/2 bag mix. Provide additional reinforcing, thickness, etc. as use requires.
  - b. Sidewalk widths on campus shall be as outlined in **Appendix F – Site, Landscape and Irrigation Design Requirements**. Central slab thickness shall be 6- in thick, and grow to 8-in thick at both edges. The width of the thicker edge on each side of the sidewalk shall not be less than 6-in. Six inches from the sidewalk edge, the 8-in thick concrete shall taper approximately 45° from 8-in to the 6-in central slab thickness.
  - c. All sidewalks shall include polypropylene multifilament fiber reinforcement.
- B. Site Grading
- (1) Finish Floor Elevations: Establish finish floor elevations 6" above the finish grade adjacent to the building. Provide 2% minimum positive grade away from the building for at least 12'.
  - (2) Demolition
    - a. Require the removal of existing objects, not designated to remain, down to the subgrade. Direct the Contractor to remove designated objects and material from the construction site and University property in a neat, orderly and legal manner.
    - b. On-site burning is not permitted.
    - c. Explosives are not to be used without approval from Facilities Management. Any perceived need to use explosives will require extensive review in advance, and shall not be organized without written approval from the University Project Manager. If approved, allow ample time for University notices and preparation.
    - d. Rock/cobbles up to 30-inches in diameter are considered ordinary earthwork. When unexpected rock removal is required, direct the Contractor to notify both the A/E and the University Project Manager.
- C. Storm Water Management Plan
- (1) General Requirements
    1. The design team shall:
      - a. complete the University's Utah Pollution Discharge Elimination System (UPDES) submittal form for Long Term Stormwater control compliance
        1. Describe why the specific long-term storm water controls were selected, the pollutant removal expected from the selected controls and the technical basis that supports the performance claims for the selected controls. For a copy of this form, please see the forms section on the University's Documents and Standards web page ([https://pdc.utah.edu/aec/#design\\_resources](https://pdc.utah.edu/aec/#design_resources)).
        2. Provide a detailed design basis for proposed stormwater features (flow detention, attenuation, water quality, etc).
        3. Provide long-term maintenance requirements of installed stormwater features, e.g. buried vault filters, cleaning schedule, etc.
      - b. Include in the specifications that the CONTRACTOR shall
        - ii. Follow all laws, and the University Stormwater Management Program Plan
        - iii. Receive training from the Environmental Health & Safety Department
        - iv. Submit plans to University Project Manager, and the Environmental Health & Safety Department for review
          1. Over an acre – full SWPPP
          2. Under an acre – Erosion Control Plan
        - v. Received all applicable permits
          1. Provide documentation to University Project Manager of NOI and NOT
        - vi. Identify a qualified party for SWPPP/Erosion Control Plan planning and implementation.
          1. Party should perform a pre-mobilization inspection of the local stormwater features to document existing system conditions.
          2. Party shall provide proactive site inspections as required by the permit.
          3. Site inspections shall be documented, with documentation available for review at any time by University Project Manager or EHS Department.
      - a. Maintenance and Escalation of Best Management Practices



### 3.# Geotechnical

#### A. Earthwork

##### (1) Soils Reports for University Projects

- a. All new building, parking or roadway projects shall include soils investigations performed by a professional geotechnical engineer qualified and licensed for such work.
- b. The A/E shall provide the geotechnical engineer with the following items:
  - i. A preliminary site plan showing new improvement locations with finish floor and finish grade elevations.
  - ii. A general description of the type of structure or facility to be constructed.
  - iii. Pavement locations and instructions for any needed pavement sections.
  - iv. Specific areas where potential infiltration would suggest permeability testing, with specific testing locations and associated depths.
- c. The geotechnical engineer shall provide a report of its investigative findings, and shall include all information required by State adopted codes.
  - i. The report shall contain an evaluation of on-site soils and their suitability for use in construction of the building or other improvements. All on-site material shall be recycled to the greatest extent possible to limit import/export and meet the University's sustainability goals (<https://climate.utah.edu/>).
  - ii. The report shall prioritize the use of onsite soils and any soil amendments to reduce import/export.
  - iii. The report shall include recommendations for the modification of non- acceptable soils for reuse on site.
  - iv. The report shall indicate appropriate locations where on-site soils can be used (i.e., trench backfill, subgrade below exterior flatwork and/or site paving, structural backfill, etc.).
  - v. The report shall indicate soil suitability for storm water infiltration and include infiltration rates and recommended methods based on permeability testing.
  - vi. The report should contain recommendations for at least one foundation drain system and describe precautions to be taken for special problems such as expansive soils, collapsible soils, etc.
  - vii. Special attention is to be given to the possibility of expansive soil conditions.
  - viii. In roadway or parking lot areas, the report shall contain recommendations for roadway and parking lot cross sections including asphalt or concrete thickness and thickness of accompanying road base.
    - a. Pay particular attention to areas where the asphalt or concrete paved surface will be subject to heavy loads. The pavement section may require special design to ensure long use with minimal maintenance. Consult with Facilities Management through the University Project Manager to determine where heavy use design will apply.
    - b. As an alternate for University consideration, the report shall include at least one pavement section that incorporates rubberized asphalt (at a minimum as a top layer), or pervious (gap graded) asphalt or concrete. The A/E will consult with Facilities Management through the University Project Manager about the possibility of including at least one section as an alternate bid item in the bidding documents. Options might include pervious concrete, 6" asphalt over 8" road base, pervious concrete over 18" gravel, etc.
  - ix. The report shall have a specific section addressing site specific sustainability recommendations to support the University's sustainability goals and climate change concerns.
- d. The A/E shall modify project plans and specifications appropriately to incorporate the soils engineering firm's recommendations.

##### 2. Backfill

- a. To the greatest degree possible, on-site materials are to be evaluated for suitability as structural backfill. The University desires to use on-site materials to the greatest degree possible as long as there is no loss of quality or stability.
- b. The A/E should carefully define minimum acceptable standards for structural backfill, and quantify on-site sources of acceptable material.

- c. Minimize the potential for change order cost issues by including material unit prices on the bid form. These unit-cost items should be clearly described in the measurement and payment section of the specifications. Coordinate unit pricing and alternate pricing schemes with Facilities Management through the University Project Manager during design.
3. Excavation
- a. Alternate Storage Site: Specify that any excavated soil identified for use as backfill is to be stored at the project site. Where this is not feasible, an alternate temporary storage site should be arranged with Facilities Management through the University Project Manager. Such storage shall be discussed and arranged with Facilities Management early in the design process.
  - b. Soil Not Usable as Backfill: Direct the Contractor to remove and legally disposed of any excavated soil not identified for use as backfill. There will be no permanent dumping on University property
4. Compaction
- a. Specify that backfill shall be properly laid and compacted in lifts to the following standards. Where specific compaction recommendations are included in the soils report for the project, the soils report recommendations shall be followed in lieu of the following standards.
    - i. In lawn and landscaped areas: 85% of maximum dry density, 12-inch layers.
    - ii. In sidewalks, roads, parking areas or under buildings: 96% maximum dry density, 8-inch layers.
  - b. Compaction testing shall be required. Coordinate the need for anticipated testing with the University Project Manager who will arrange a contract for the services of an independent testing firm. Note: The first test will be provided by the University, but any retesting due to test failure will be at the Contractor's expense.
    - i. The A/E shall include testing requirements for the Contractor and the testing firm in the project specifications. Duties of the University's testing firm should also be made a part of the specifications.
    - ii. Specifications shall indicate the testing frequency and type.
    - iii. Include in the specifications, "Failure of Facilities Management or the A/E to detect defective work or material does not prevent later rejection of the work, nor obligate the A/E for final acceptance when such defective work or material is discovered."
    - iv. Include in the specifications a list of informational items required for submittal.
    - v. A test schedule shall be included in the specifications.
      - a. Curb and gutter with grade less than 0.5%: One random test per lift per 200 lineal feet.
      - b. Curb and gutter with grade greater than 0.5%: One random test per lift per 400 lineal feet.
      - c. Sidewalk: One random test per lift per 400 lineal feet.
      - d. Trenches: One random test per lift per 200 lineal feet.
      - e. Roadways: One random test per lift per 1000 square yards.
      - f. Landscape Areas: No specific requirements.
  - c. If lawn and landscaped areas that have passed compaction test are subsequently subjected to activities that would increase compaction (e.g. driving vehicles), additional compaction tests shall be performed at the Contractor's expense.
-

### 3.3 Architectural

#### A. Daylight and Outside Views

1. Daylight and outside views are desirable for all occupied spaces. The needs of some occupied spaces may require special consideration for light control.

#### B. New Roofing Requirements

\* For roofing of new construction, roof replacements, or for any work modifying existing roofing or roof-top equipment installations, refer to DFCM Roofing Program requirements: <https://dfcm.utah.gov/wp-content/uploads/2023-Roofing-Design-Requirements-2.21.23.pdf> , and to the drawings collected at <https://dfcm.utah.gov/wp-content/uploads/Full-Set-DFCM-Roofing-Details-2-23.pdf>

\*\* In addition to DFCM Roofing Requirements for review and inspection by DFCM Roofing Program Manager, U of U Roofing Asset Manager is also to review (prior to submission for code review) plans, specifications, and details for any new or replacement roofing, or for any work to modify existing roofing or roof-top equipment installations. Review via Blue Beam studio session preferred. Roofing asset manager should also be included in the roofing pre-installation meeting and substantial completion and final inspections of roofing and roof-top equipment installations.

1. Comply with Contractor Roofing Warranty: Include DFCM requirements. Refer to [dfcm.utah.gov/wp-content/uploads/CRWform.pdf](https://dfcm.utah.gov/wp-content/uploads/CRWform.pdf)
  - a. Modifications shall not negatively impact existing warranties and shall themselves carry a 5-year workmanship warranty.
  - b. At each roof access point, provide required warranty signs as specified in DFCM Roofing Standards, but with contact information as provided by U of U Carpentry.
2. Comply with Guaranty for Bituminous Roofing: Include DFCM requirements. Refer to [dfcm.utah.gov/wp-content/uploads/bituminous\\_roof\\_warranty.pdf](https://dfcm.utah.gov/wp-content/uploads/bituminous_roof_warranty.pdf)
3. Comply with Guaranty for Single-Ply Roofing: Include DFCM requirements. Refer to [dfcm.utah.gov/roofing-program/](https://dfcm.utah.gov/roofing-program/)
4. Comply with the list of DFCM approved manufacturers and approved installers.
5. Where manufacturer's standards show one or more possible approach for compliance to the standard, provide their most stringent approach.
6. Eliminate conflict between roof penetrations (i.e. vents, exhausts) and roof crickets, flashing, and valleys. Consider relocating penetrations to less visible areas. Provide 18" access for replacing roofing components.
7. In new facilities, build slope into roof structure in lieu of built-up insulation to solve roof drainage issues.
8. Minimum slope for all roofing and waterproofing systems shall be a ¼" per foot, with a preference of 3/8" per foot, along the longest drainage path.
  - a. Roof slopes greater than 2:12 shall be an architectural laminated shingle or a standing seam metal roofing system.
9. Do not provide the following components, unless approved by the Director: Other Roofing Components: ballasted roofs.
10. All roofing systems and components should meet or exceed all ASTM, UL and FM requirements.
11. Minimum 60 mil thickness required for all single ply roofs.  
Minimum 4-ply, type VI felts with type III asphalt for all built-up roofs.

12. All metal associated with the roof should be color clad, use standing seam joints where possible. Follow SMACNA guidelines for all metal work.
13. Provide reasonable access to all roof levels for maintenance personnel.
  - a. All roof areas must be accessible via secured walk out door (strongly preferred) or secured fixed ladder access.
    - i. All means of roof access shall be keyed to the University roof master key. Requirements for master keys will be set by the UofU key shop.
  - b. Walk pads must be installed at all roof entry points including the tops and bottoms of ladders between levels, at roof access doors, at the front edge of roof hatches, around all equipment on the roof, and along the route connecting the roof access point to equipment or other traffic required routes.
  - c. Provide roof-to-roof ladders for any stepped or steeply sloped changes in roof elevation greater than 2 feet, including over intervening parapet walls. Ladders and stairs to meet requirements for structural attachment to deck, flashing into roof surface, and clearances underneath (excepting clearance under lowest rung or tread, which should be 12" above roof surface).
  - d. Roof access ladder and hatch should be located in a dedicated access closet, custodial closet or mechanical room (Facilities managed space that can be cross-keyed to roof access key).
  - e. Hatch size should be limited to 30" x 36" or 36" x 36".
  - f. If a larger hatch in a stairwell location is required by others, it should be in addition to one meeting the above specifications.
14. Steep slope roofing should be designed as directed by the DCM Program Manager.
15. Comply with all other minimum standards as published by the DFCM roofing group.
16. Roofing Systems
  - a. 80-mil or thicker shall be used for areas with mechanical equipment or other areas requiring heavier traffic. Ballasted roofs are not allowed. ii. Georgia-Pacific "DensDeck" roof boards or prior approved equal shall be specified as underlayment between the insulation and the membrane where more than light or occasional foot traffic is anticipated.
  - b. Planted roofs, pavers, decking, and other overburden may be installed only over fluid-applied plaza waterproofing systems (not over single-ply membrane roofing). Extensive use of pedestal paver systems discouraged. [Ref. updated requirements for planted / softscape areas on plaza areas?]
    - i. The built-up modified asphalt system under overburden shall include appropriate protection boards, drainage layers and drain protection methods.
  - c. Solar panel arrays must meet requirements stated elsewhere for structural attachment to deck, routing of conduit runs, and clearances underneath (also incorporating walk-paths between panel rows). Prioritize solar parking structures (or other means of capturing solar benefits) over roof-top installations. Prioritize solar arrays integrated into design of new construction over retrofitting of arrays on existing roofs.
17. Roof Drainage
  - a. Roof drain domes shall be metal. Acceptable brands are Zurn, Wade, Smith, and Josam, or equal.
  - b. Primary drains must be sumped below the main roof drainage plane.
    - i. If these non-standard methods of primary drainage are approved by variance, the design shall include heat trace equipment.
  - c. Drain sumps shall not be obstructed by equipment, overburden, or pavers.
  - d. Refer to DFCM Roofing Standard Details for additional rainwater/roof drainage details.
  - e. Only single-piece drain bowls allowed. If drain bowl needs to be elevated above roof deck, this should be achieved with blocking under the bowl, not by stacking multiple bowl sections or using adjustable 2-piece bowls.
18. Conduit and Pipe Supports
  - a. Exposed wood is not allowed on roof areas. Roof mounted pipe and conduit runs across roof surface are not allowed.
19. Rooftop Mechanical Equipment

- a. Rooftop equipment, including temporary installations, must be clearly and durably labeled with asset information (if Facilities maintained equipment) or owner group and contact information (if owned by Departmental or outside entity).
  - b. Electrical routing through roof surface must be via rigid or EMT conduit to a point above the flashing termination. Conduit must be securely fastened below the deck. Routing through deck must be immediately adjacent to end use point (no conduit runs across roof).
  - c. At replacement of curb-mounted, non-ducted equipment (or when re-roofing around same), re-use of the curb may be allowed (in lieu of upgrading to post / platform standard), but cap must be replaced if there are any existing penetrations through the top surface. Review with roofing asset manager.
  - d. Package units (air handlers on ducted curbs or pre-fabricated mechanical penthouse structures) must have a roof that is either sloped standing-seam metal or single-ply membrane over rigid coverboard and meeting all other requirements (including warranties) for single-ply roofing systems. Roof should not drain over air intake or relief louvers.
  - e. Equipment or platforms on stands must have the required 18" of clearance underneath, increasing to 24" height if the area underneath is wider than 3 feet. Extensive platforms or areas of raised equipment should be elevated to 7' above the roof surface (or integrated into a penthouse structure).
  - f. Penthouses with substantial mechanicals should be accessed directly by elevator (avoiding cross-roof transport of high-voltage motors, pumps, etc.)
20. Equipment on Existing Roofs - Mechanical Units, Curbs and Other Roof Top Equipment
- a. Mechanical equipment located on a roof must be durably labeled with UofU asset information and supply circuitry information. Temporary installations must be durably labeled with owner and departmental name and contact information.
  - b. Require the contractor to notify the University Project Manager and Carpentry Shop when existing roof mounted equipment lacking labeling is encountered so that labeling or removal/disposal as appropriate can be pursued.
- C. Roofing Requirements – Please see the DFCM Roofing website for a detailed description of the latest roofing design criteria and requirements at [dfcm.utah.gov/roofing-program/](http://dfcm.utah.gov/roofing-program/). If for any reason, you are having difficulty accessing the page above, please contact DFCM immediately.
1. Partial Replacement or Extension of an Existing Built-up Roof (BUR)
    - a. The termination (top edge) of the roofing plies must be at least 8-in above the roof surface in the immediate vicinity.
    - b. All transitions from horizontal to vertical in the roofing plies or cap sheets of a BUR system require the use of cant strips to eliminate 90-degree bends. To further avoid such bends, BUR plies and cap sheets shall not be wrapped over the top of curbs or parapets unless specifically designed for this purpose by the manufacturer.
    - c. All materials used in the creation of a BUR system, detail, or tie in must be protected from UV exposure by the use of aluminized roofing paint (silver coat), or properly imbedded granules, or the use of a compatible and purpose-made foil flashing.
    - d. Any exposed mastic must be finished to a smooth surface and feathered edges.
- D. Waterproofing and Sealants
1. Warranty: For sealant systems, guarantee both labor and materials for a minimum of two years. For waterproofing project, guarantee both labor and materials for a minimum five years.
  2. Qualifications: For Damp proofing and Waterproofing, select products that have performed successfully for a minimum 15 years and select manufacturers that have been producing materials for 15 years.
  3. Fluid-Applied Waterproofing
    - a. For all foundation /retaining walls (including walls which do not carry a building load and for slab-on-grade foundation walls) and for all underground horizontal structures (new and remodeled), provide the following:

- i. Specify a complete hot or cold applied waterproofing assembly, a fluid applied product over membrane system obtained from a single source manufacturer, and which will meet or exceed a 20 year guarantee/warranty and to comply with ASTM D412-06a, ASTM C836 / C836M-12.
  - a. The assembly shall have a proven record of superior performance commensurate with the 20 year guarantee/warranty and shall include surface conditioner (primer); adhesives and sealants; a monolithic (no seams) fluid applied waterproof membrane, drainage and protection board; Flashings, reinforcing fabric; drainage course, filter fabric, flexible waterproof boots; and perforated pipe adjacent to the base of the footing.
  - b. A fully compatible electronic field vector mapping testing system shall be specified on any plaza type project requirement waterproofing on horizontal applications.
  - c. All products used in the waterproofing system intended for a project are required to be the products of one manufacturer or part of the warranted system of the manufacturer (with one exception, the vector mapping system; however, the vector mapping system shall be certified to work with the intended system.
- ii. Before the Contractor orders waterproofing materials, require submittals describing the system and installer. Submittals are to be submitted through the A/E and University Project Manager to Facilities Management for approval. Include the following as a minimum:
  - a. A complete description of the fluid applied system assembly.
  - b. Verification that all products are from one manufacturer except the vector mapping system.
  - c. Verification that each product in the manufacturer's wall protection assembly must be manufactured for the intended use; and must be fully compatible with all other materials which will be used in the manufacturer's waterproofing assembly.
  - d. Certification that the vector mapping system is compatible and fully functional with the intended fluid applied waterproofing system.
  - e. Manufacturer's certification that the installer is fully qualified to apply the manufacturer's products to meet a 20-year warranty.
  - f. A written commitment that a manufacturer's rep will be present on-site monitoring and inspecting the installation as it proceeds, and will submit regular reports to the A/E and University Project manager certifying compliance to manufacturer's installation requirements.
- b. Damp-proofing will not be allowed. Specify the following minimum installation requirements:
  - i. Top of the waterproofing assembly will be 6-in below finish grade.
  - ii. The drainage and protection board is to be applied over the fluid applied waterproofing membrane.
  - iii. Gravel fill shall be a minimum of 12-in thick and protected with a filter fabric between the gravel and surrounding soil.
  - iv. The filter fabric must completely envelope the gravel and perforated pipe from the wall surface near the top, along the outer gravel boundary, around the gravel base containing the perforated pipe, and terminating over the flashing at the footing base.
  - v. The upper fabric connection at the top of the gravel fill must be affixed to the drainage/protection board.
  - vi. The lower fabric connection near the bottom of the gravel fill must be affixed to the drainage/protection board above the footing.
  - vii. Specify either a 4-in or 6-in diameter perforated pipe at the base of the footing in the gravel. Engineer the pipe to meet the anticipated soil moisture conditions.
  - viii. Direct the contractor to set the top of the perf-pipe below the top of the footing.
  - ix. Fluid applied waterproofing is to be applied in two directions. The horizontal application shall be installed with reinforcing fabric to a thickness of 215-mil. The vertical application shall be installed to a thickness of 180mil applied in two 90-mil applications.
- c. Guarantee/Warranty
  - i. At the conclusion of the installation, require the manufacturer's rep to certify verification that the installed system is leak free; that the membrane application is tight without voids; and that the system assembly including the applied mil thickness meets the manufacturer's requirements for the 20-year guarantee/warranty period.

- ii. Before accepting the installation for plaza (horizontal) applications, require the installer or manufacturer’s representative to demonstrate to the A/E, University Project Manager, and DFCM Roofing Program Manager complete functionality and continuity of the vector mapping system within the completed waterproofing system.
  - iii. The guarantee shall include the cost of materials and labor (no dollar limit and not pro-rated), and include the removal and reinstallation of landscaping, soil, paving, etc., to access the area to be repaired/replaced.
  - iv. If during the 20-year period, either the manufacturer or contractor goes out of business, the other is required to assume full responsibility for the guarantee/warranty.
4. Joint Sealants
- a. For joint sealants in above-grade concrete walls, metal window walls (i.e. curtain walls), and in-between concrete and metal elements use silicone sealant equal to Dow 790, Dow 795, Sika WS 290, or Sika WS 295.

**E. Acoustical Quality**

1. When possible, design spaces in accordance with following minimum requirements for “Privacy.”

Privacy	
Space Category	Measured NIC Rating
Confidential with high voice levels	58-60+
Confidential with slightly raised voice levels	52-58
Confidential with normal voice levels	50-52
Confidential with lowered voice levels	45-50

2. Design spaces in accordance with the following minimum requirements for “Ambient Background Noise.

Ambient Background Noise	
Space Category	Measured NC Rating
Critical Performing Spaces	<20
Performing Spaces, Courtrooms, Executive Offices	20-30
Sleeping, testing, or relaxing spaces	25-35
Private offices, small conference rooms, classrooms, libraries	30 -35
Open offices, reception areas, cafeterias, gymnasiums	35-40
Lobbies, laboratories, maintenance shops	40 -45
Kitchens, industrial shops, equipment rooms	45-55

- 3. Classroom walls shall be designed to STC (Sound Transmission Class) 50 minimum. Spaces with even higher sensitivity shall be designed to STC 55 minimum.
- 4. Ceiling materials in halls and lobbies with carpeted floors shall have an NRC (Noise Reduction Coefficient) of at least 0.5. Ceiling materials in halls and lobbies with hard floors shall have an NRC of at least 0.65.
- 5. An acoustical engineering consultant for special use halls, classrooms, and lecture spaces is recommended. Obtain services before shape of space is fixed.

**F. All Gender Ready Restrooms**

- (1) Where allowed by this section, the design for all gender ready restrooms shall be in compliance with the current adopted building codes and state amendments found in Title 15A of the Utah State Code.

Multiple-user restrooms:

- (2) DFCM allows one all gender ready multiple-user restroom per building. This restroom shall

- be located on a floor with public access.
- (3) Each all gender ready multiple-user facility shall include a floor to ceiling demising wall and must be approved in writing by the DFCM Director prior to removing the demising wall once opened as an all gender multiple-user facility.  
The demising wall shall be a demountable, floor to ceiling height with no gaps at the perimeter. Signage identifying the restroom facility as all gender shall be provided and comply with signage requirements per the ADA and all applicable codes.
    - a. All doors going into multiple-user restrooms should have an auto power operator and outside and inside buttons to activate the opener. If there are multiple doors for entry/exit, this set-up should be on at least on one of the doors for entry and exit
  - (4) All gender ready multiple-user restroom shall be designed with two exits and no dead ends. Common areas shall include multiple lines of sight.
  - (5) Each individual all gender ready multiple-user stall shall provide full height, floor to ceiling partitions. In stalls where a urinal will be replaced, the urinal stall door shall not be installed and shall be provided to Owner for storage until the demising wall is removed.
  - (6) Each all gender ready multiple-user facility shall include individual doors with occupancy-vacant/occupied notification and dead bolt locks. Individual toilet compartment doors shall be gapless.
  - (7) Each individual all gender ready multiple-user stall shall be equipped with a floor drain.
  - (8) Each individual all gender ready multiple-user stall shall be equipped with an exhaust fan meeting the ventilation requirements of International Mechanical Code.
  - (9) Each all gender ready multiple-user facility that incorporates urinals shall be designed to facilitate plumbing for a toilet in lieu of the urinal once opened as an all gender multiple-user facility.
  - (10) Sanitary napkin disposal units should be placed in every stall once the all gender multiple-user stalls are open for use.
  - (11) Each all gender ready multiple-user stall and sink area shall have occupancy sensors. A single relay shall control both sides of the restroom so the lighting in all stalls and sink areas will auto-on when occupancy is detected by any of the occupancy sensors.
  - (12) The DFCM Director shall be notified and approve in writing, the removal of the demising wall. When the demising wall is removed and multi-user restrooms are created, all doors to public spaces from the restroom space shall be removed and the signage modified to reflect the all gender use.
  - (13) The agency may design all other multi-user restrooms to be configured similar to the “All Gender Ready Restrooms” (excluding the requirements of 3.3.F.2-12) so they could be modified to All Gender in the future. Future conversions must be approved in writing by the DFCM Director.
  - (14) New – Multiple-user restroom signage



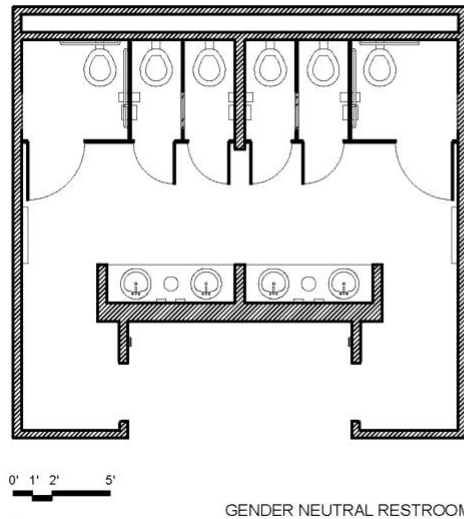

NOTE:

Urinal to be replaced with toilet. Stall door to be installed. Toilet paper dispenser and sanitary disposal to be installed.

Demising partition to be removed.

Doors to common space shall be removed.

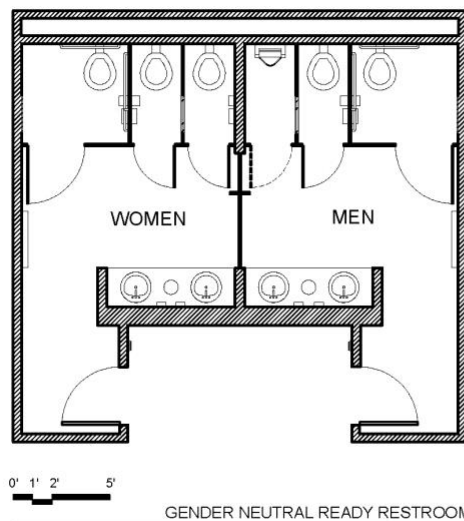

NOTE:

All applicable Codes and Standards which may include:

Stall partitions to be full height (floor to ceiling). Note urinal stall door shall not be installed and stored by owner.

Demising wall to be a demountable partition (no gaps at perimeter).

Each stall to have its own individual exhaust.

Each stall to have means of transfer air for exhaust. This can be through either a ceiling grille-to-ceiling grille transfer duct or sight-proof transfer grille on restroom partition (minimum 1-3/8" thick panel).

Each stall to have its own floor drain.

Urinal to be plumbed with larger pipe sizes (4" Sanitary Waste, 2" Vent) to facilitate changing to water closet in the future.

Each stall and sink area will have occupancy sensors. A single relay will control both restrooms so the lighting in all stalls and sink areas will auto-on when occupancy is detected by any of the occupancy sensors.

Each stall will have its own fire alarm strobe.

Single-user all gender restrooms:

- (15) Single user all gender restrooms shall be permitted and allowed to be signed as an all gender restroom. The design for an all gender single user restroom shall be in compliance with the current adopted building codes and state amendments found in Title 15A of the Utah State Code.
- (16) Each single user all gender restroom shall include doors with occupancy- vacant/occupied notification and dead bolt locks.
  - a. Mortise lock with a deadbolt shall be included with signage. All signage must be able to be seen at least 2ft away from door.
  - b. When locks have a key, locks will be keyed to the customer and mechanical keys for each building.
- (17) Sanitary napkin disposal units should be placed in every single user all gender restroom.

**G. Building Graphics**

1. Exterior Building Graphics
  - a. The A/E shall coordinate with the University Project Manager & University Campus Planning regarding the latest copy of the Design Standard Document.
2. Interior Building Graphics
  - a. This item includes room numbers, room names and a standard building dedication plaque.
    - i. All room numbers MUST have final approval from Space Planning and the University of Utah Project Manager **prior** to being released for fabrication.
  - b. Academic Branding. If the building interior is designed using a coordinated functional branding theme, room identification graphics, way finding graphics, International Building Code, ADA, directional graphics, etc., will require review and approval by Facilities Management early in the design.
  - c. The following are examples of the University standard for interior sign graphics:
    - i. Sign Type A1/00 – Small Door ID Sign. Painted acrylic backer with square edges and modified acrylic sign face with square edges, Braille beads and applied machine engraved tactile graphics:

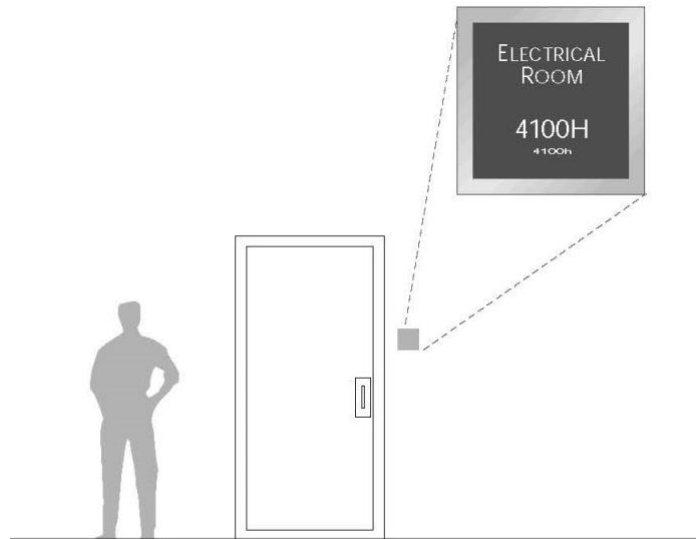

SIGN TYPE A1/00 - Small Door ID Sign

Painted acrylic backer with square edges and modified acrylic sign face with square edges. Braille beads and applied machine engraved tactile graphics.

- ii. Sign Type A3/00 - Large Door ID Sign. Painted acrylic backer with square edges and modified acrylic sign face with square edges, Braille beads and applied machine engraved tactile graphics.

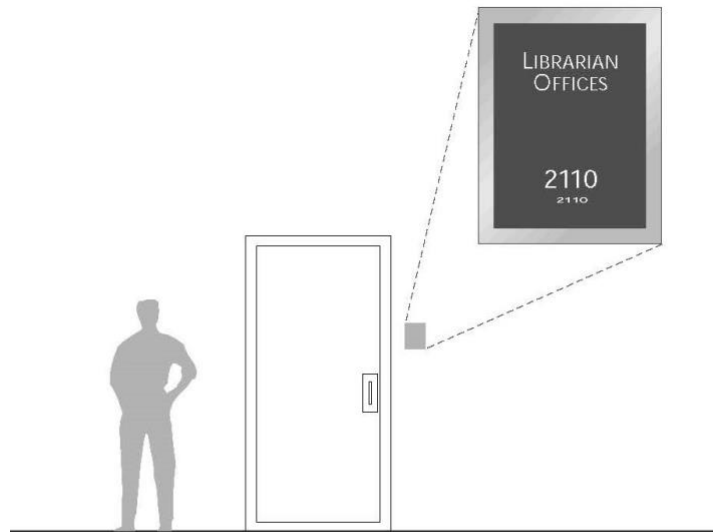

SIGN TYPE A3/00 - Large Door ID Sign

Painted acrylic backer with square edges and modified acrylic sign face with square edges. Braille beads and applied machine engraved tactile graphics.

- iii. Sign Type A4/00 – Small Door ID / Changeable Painted acrylic backer with square edges and multi-layered modified acrylic sign face with square edges, routed window and Braille beads and applied machine engraved tactile graphics. Window for printed paper insert.

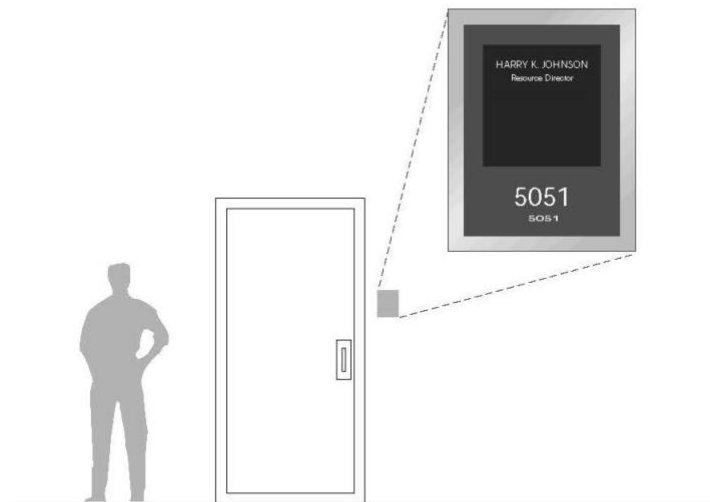

SIGN TYPE A4/00 - Small Door ID / Changeable

Painted acrylic backer with square edges and multi-layered modified acrylic sign face with routed window and square edges. Braille beads and applied machine engraved tactile graphics. Window for paper insert.

- iv. Sign Type A5/00 – Medium Door ID / Changeable. Painted acrylic backer with square edges and multi-layered modified acrylic sign face with routed window and square edges, Braille beads and applied machine engraved tactile graphics. Window for printed paper insert.

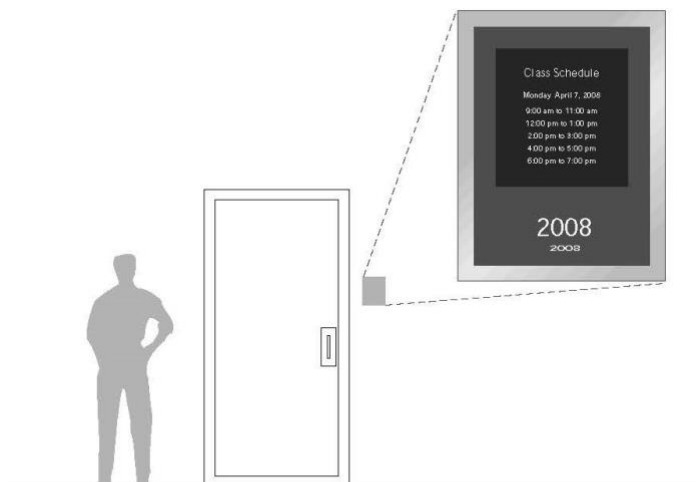

**SIGN TYPE A5/00 - Medium Door ID / Changeable**

Painted acrylic backer with square edges and multi-layered modified acrylic sign face with routed window and square edges. Braille beads and applied machine engraved tactile graphics. Window for paper insert.

- v. Sign Type A7/00 – Restroom ID / Women. Painted acrylic backer with square edges and modified acrylic sign face with square edges, Braille beads and applied machine engraved tactile graphics.

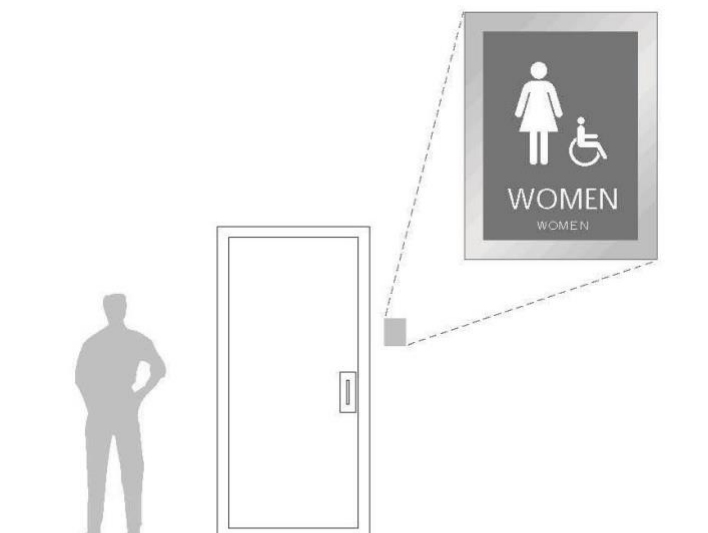

**SIGN TYPE A7/00 - Restroom ID / Women**

Painted acrylic backer with square edges and modified acrylic sign face with square edges. Braille beads and applied machine engraved tactile graphics.

- vi. Sign Type A11/00 – Stair Code Sign. Modified acrylic sign face with square edges, Braille beads and applied machine engraved tactile graphics.



**SIGN TYPE A11/00 - Stair Code Sign**

Modified acrylic sign face with square edges. Braille beads and applied machine engraved tactile graphics.

- vii. Sign Type A12/00 - Single Use Restroom (family or assisted use) Sign. Lettering shall state “All Gender Restroom”. Painted acrylic backer with square edges and modified acrylic sign face with square edges, Braille beads and applied machine engraved tactile graphics. Corners may be radius or square to match other sign types.

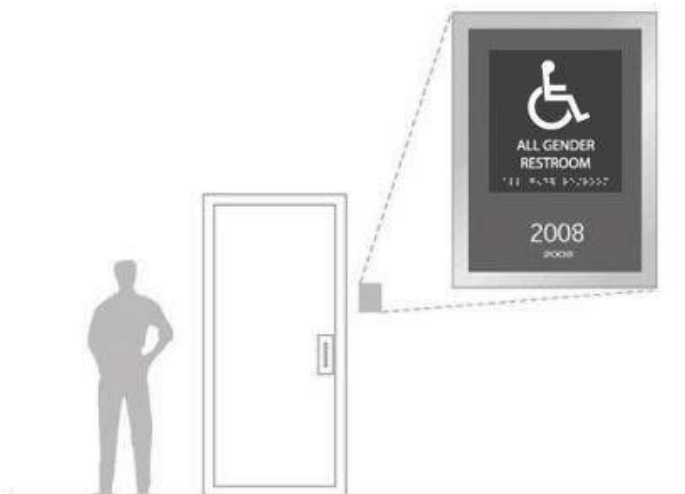

**SIGN TYPE A12/00 – Medium Door ID / Changeable**

Painted acrylic backer with square edges and multi-layered modified acrylic sign face with routed window and square edges. Braille beads and applied machine engraved tactile graphics. Window for paper insert.

## H. Custodial Closets

### 1. General Requirements

- a. Space for three separate custodial closet functions shall be included in every building. Individual rooms shall be provided for one or more wet closets, one or more dry closets, and one office closet.
- b. For existing buildings, the A/E's design responsibilities for building alterations and/or additions shall include a review of the entire building's custodial conditions with regard to the requirements described herein. The project scope for the remodel and/or addition shall include additional custodial space where needed to meet the building's overall custodial space requirements.
- c. Access to each custodial closet/office shall be along a direct route from a main hallway.
- d. Each custodial closet/office door shall have means to hold the door in the open position (i.e., door closer with hold open push arm) as allowed by code. Requirement not met by door stop at the bottom of the door.
- e. Closet floors shall waterproof and slip resistant, sealed and cleanable surface treatment.
- f. Each closet shall have a Storeroom function lock

### 2. Wet Closets

- a. Each wet closet shall be centrally located in its service area.
- b. The minimum footprint for each wet closet shall be no less than 80 square feet with the shortest wall length no less than 6 feet.
- c. The door width for each wet closet shall be 36-in unless requested otherwise by Campus Custodial Services. All wet closet doors shall swing out, not into the custodial space.
- d. For floor areas per level equal to, or less than 40,000 gross square feet, provide one wet closet per floor level.
- e. For floor areas per level greater than 40,000 square feet, the project design must include additional wet closets (one for each 40,000 gross square feet or portion thereof).
- f. When multiple wet closets are provided on a floor level, divide the floor into equal service area segments and locate each closet centrally in its service area, preferably near restrooms.
- g. The design shall include a floor mounted service sink with a minimum size of 15 square feet. The edge of the sink shall be no higher than 6-in above the finished floor. Waterproof wall protection shall be provided at floor mounted sink locations.
- h. The design shall include a wall mounted hanger rack for wet mops (minimum of four hangers) which shall be installed over the service sink.
- i. The design shall include adequate wall space for a chemical dispensing system which will be located over the service sink. Minimum wall space required is 2-ft x 2-ft, located directly over the hose bibs.
- j. The design shall include adequate clear wall space (at least 5-feet linear) for hangers to store brooms, ladder, etc.
- k. Installed along one wall of the closet, the design is to include a minimum of five (5) adjustable height shelves (adjustable from floor to ceiling). Shelves shall be 14-in deep. Do not locate the shelving system behind a door.
- l. Include a minimum of one electrical outlet in each wet closet, installed in an approved location.
- m. Include an outlet for CleanCore Fill Station wall unit within 36" of the fixture.

### 3. Dry Closets

- a. Each dry closet shall be centrally located in its service area.
- b. The minimum footprint for each dry closet shall be no less than 200 square feet with the shortest wall length no less than 8-feet.
- c. The door width for each dry closet shall be 42-in unless requested otherwise by Campus Custodial Services. All dry closet doors shall swing out, not into the custodial space.
- d. For buildings equal to, or less than 150,000 gross square feet, provide one dry closet per building.
- e. When the building exceeds 150,000 gross square feet, a second dry closet of the same size shall be provided. Divide the building into equal service area segments and locate each dry closet centrally in its service area.
- f. The design shall include adequate clear wall space (at least 6 lineal feet) for hangers to store brooms, equipment, ladder, etc.

- g. Installed along two adjoining walls of the closet, the design is to include a minimum of five (5) adjustable height shelves (adjustable from floor to ceiling), suitable for storing heavy items. The University Project Manager will provide to the A/E the required shelf depth for each dry closet, as directed by Campus Custodial Services (depth will generally be either 14-in or 18-in). Each wall's installation of the two adjoining shelving systems shall be no less than 6-feet long. Do not locate the shelving system behind a door.
  - h. The design is to include a 6-ft high x 5-ft wide x 14-in deep (minimum size) lockable cabinet that is designed specifically to store and secure cleaning chemicals.
  - i. Include two (2) GFCI four-plex electrical outlet boxes located in approved locations. These
  - j. outlets require dedicated circuits due to the nature of their use.
4. Custodial Office
- a. Each building shall have one custodial office.
    - i. For floor areas per level equal to or less than 150,000 gross square feet, the minimum footprint for the custodial office shall be no less than 120 square feet with the shortest wall length no less than 8 feet.
    - ii. For floor areas per level equal greater than 150,000 gross square feet, obtain the required minimum space dimensional requirements from Facilities Management through the University Project Manager, who will coordinate with Custodial Services. This information must be obtained early in design to avoid space and usage conflicts as the building floor plans are developed.
  - b. The design is to include either a built-in desk or sufficient room for a 60-in x 30-in desk with a three-drawer filing cabinet, furnished and installed as part of the project.
  - c. The design is to include a shelf installed on the wall above the desk. The shelf shall be 48-in long and 12-in deep. Do not locate the shelf where it will conflict with the door.
  - d. The design is to include a wall mounted staff locker system in the custodial office.
    - i. For buildings with an overall floor area (the sum of all levels) up to 20,000 gross square feet, specify four (4) full height wall mounted staff lockers in the design.
    - ii. For buildings with an overall floor area greater than 20,000 gross square feet, specify ten (10) half-height lockers in a wall mounted system.
  - e. Include electrical outlets located in approved locations for computers and electronic equipment.
  - f. The design is to include wall connections for computers, internet access, and phone service.
  - g. The custodial office may be located adjacent to a dry closet if approved by Facilities
  - h. Management and Campus Custodial Services, through the University Project Manager.
    - i. This arrangement will require separation by a wall and a door, with each space forming a complete dry closet and a complete custodial office.
    - ii. Any consideration for adjacency shall be submitted to Facilities Management early in design. A proposed layout and location for this arrangement shall be reviewed in a meeting between the A/E, the University Project Manager, and the Campus Custodial Services.

#### I. Lactation Rooms

- 1. The design for new construction, major building alterations or major building additions (defined as having a total project budget of \$10 million or more) shall comply with the lactation room requirements provided herein.
- 2. One lactation room shall be provided on the first floor of each building.
- 3. Access to the lactation room shall be along a direct route from a main hallway.
- 4. The minimum footprint shall be no less than 9-ft x 6-ft.
- 5. Doors shall be equipped with a privacy lockset
  - a. Include signage above lock that can be seen at least 3ft away from door. When keyed, it will be keyed to the customer and mechanical key for each building with a district master
- 6. Walls shall be insulated for sound.
- 7. Flooring shall be a hard surface that may be easily cleaned..

8. Walls are to be painted.
9. A countertop 2-ft depth shall be provided along one wall. The space beneath the countertop shall be open. A hand sink shall be provided in the countertop.
10. Lighting levels shall be between 30 to 50 foot-candles
11. A 110v GFI outlet shall be provided at the countertop and at the wall nearest the chair placement.
12. Each room should have the following furnishings and equipment:
  - a. One Upholstered non-caster chair with arms.
  - b. A wall mounted mirror above the counter
  - c. Soap and Paper Towel dispensers
  - d. Waste Receptacle
  - e. Wall Mounted Clock
  - f. Wall or Door Mounted Robe Hook
13. Door Signage shall be a room number

**J. Concrete**

1. Install exterior concrete stairs with tooled nosings only.

**K. Metals**

1. Steel Bollards
  - a. Steel bollards shall be minimum 6-in diameter standard steel pipe, set in minimum 24-in diameter x 48-in concrete footings, painted black with two rows of white Scotchlite reflective tape or equal spaced 2-in apart and placed 4-in below the top of the pipe. Pipe shall be a minimum of 48-in above finish grade and filled with concrete full height, with concrete mound at top, painted white. Provide sealed expansion joint around steel pipe and asphalt or concrete paving.
2. Exterior Pipe and Tube Railings
  - a. Ramp Handrails
    - i. 1.66-in diameter stainless steel handrails are to be anchored to 2.5-in square stainless steel tube posts spaced at a minimum of 4-ft on center to a maximum of 6-ft on center.
    - ii. Provide a 1.66-in diameter stainless steel bottom rail centered 4-in above finish grade between vertical posts. All connections to be welded. Handrails to be 36- in clear between rails.
  - b. Handrail Post Caps
    - i. Anti-Skateboard handrail post caps shall be .375-in x 2.5-in x continuous stainless steel plate with .25-in radius edges and be welded to a 1.9722-in diameter x .375in steel tube cap plate welded to a 1.8722-in diameter x 0.120- gauge x 2-in steel tube welded to a stainless steel cap plate welded to the top of each vertical post. See detail below.
      - a. Handrail Post Anchoring
        - i. 2.5-in square stainless steel handrail posts shall be set into 4-in diameter x 6-in deep core drilled holes in concrete paving with cementitious anchoring compound full height of core drilled hole.
        - ii. Posts shall be set a minimum of 3-in back from the paving edge or joint.
      - b. Handrail Profile
        - i. 2.5-in square stainless steel handrail post caps shall extend a minimum of 4-in above handrails. Anchor 1.66-in diameter stainless steel handrails to posts with .75-in diameter stainless steel rods, welded both ends.
    - c. Exterior Stair Handrails
      - i. 1.66-in diameter stainless steel stair handrails to be anchored to 2.5-in square stainless steel tube posts at a minimum of 4-ft on center and maximum 6-ft on center.
      - ii. Anchor 1.66-in diameter stainless steel handrails to posts with .75-in diameter stainless steel rods, welded both ends.
    - d. Handrail Details

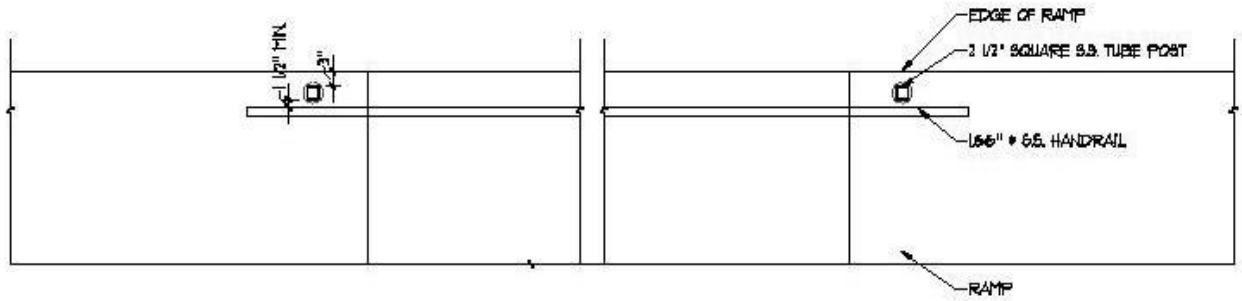

PLAN - HANDRAIL AT RAMP

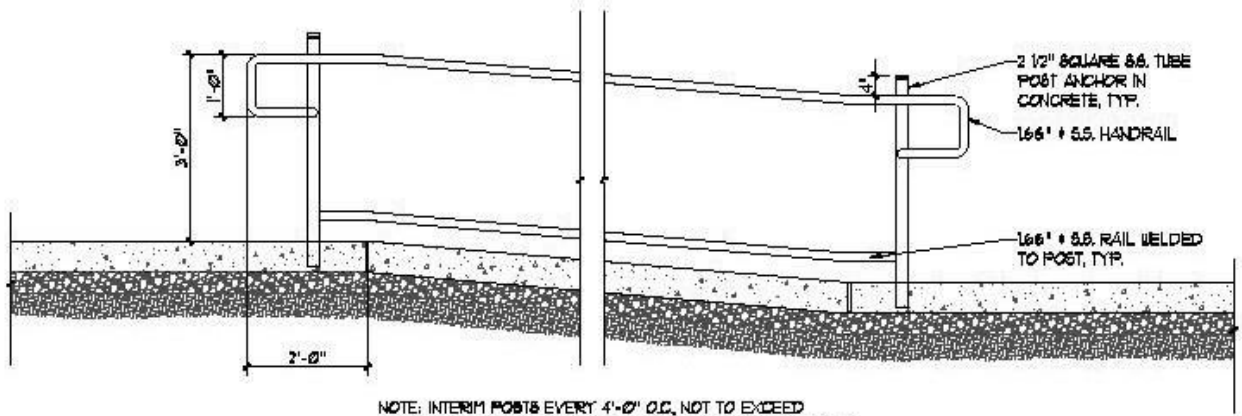

NOTE: INTERIM POSTS EVERY 4'-0" O.C. NOT TO EXCEED  
8'-0" O.C. RAMP TO HAVE 36" MIN CLEAR BETWEEN HANDRAILS

SECTION - HANDRAIL AT RAMP

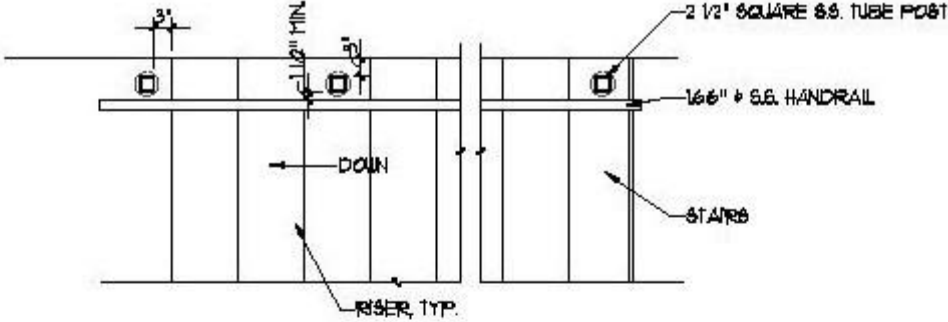

PLAN - HANDRAIL AT STAIRS

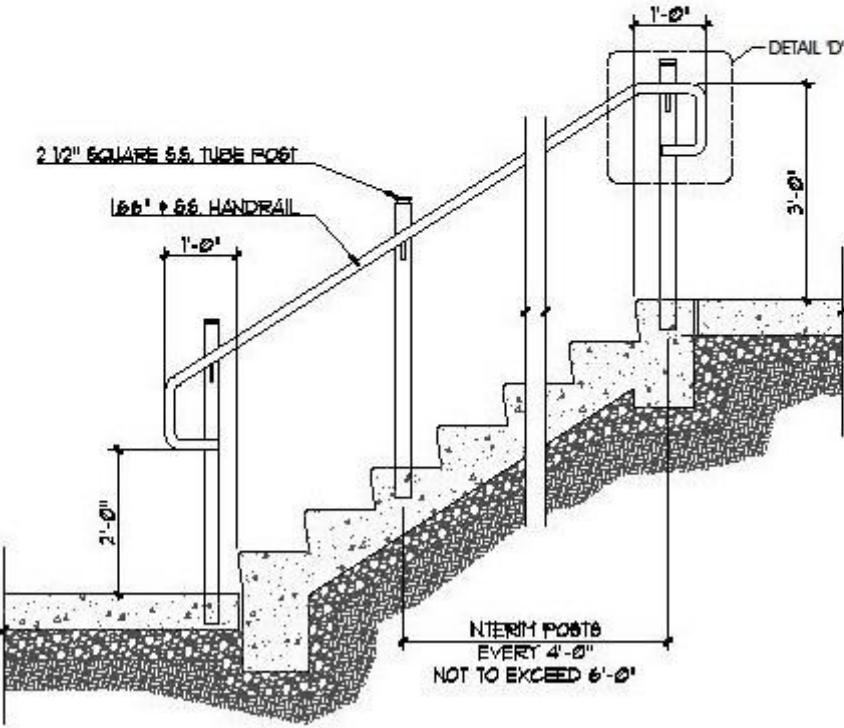

SECTION - HANDRAIL AT STAIRS

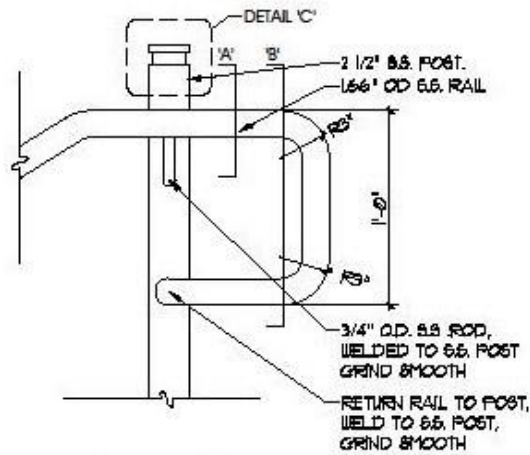

DETAIL 'D' - PIPE HANDRAIL

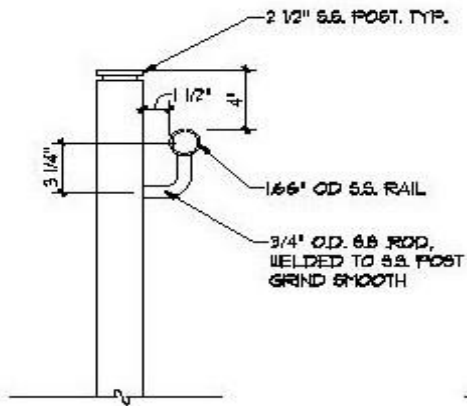

SECTION 'A'  
 PIPE HANDRAIL

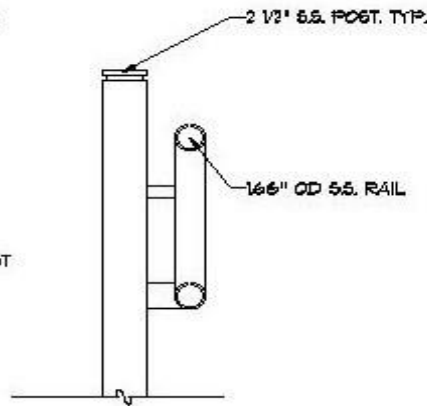

SECTION 'B'  
 PIPE HANDRAIL

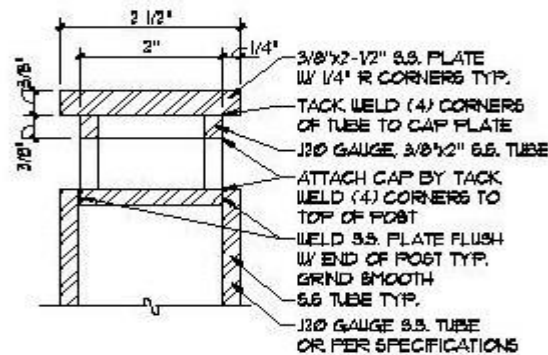
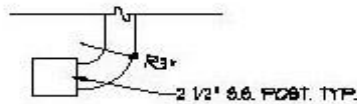

DETAIL 'C' - PIPE HANDRAIL POST CAP

## L. Wood, Plastics, and Composites

### 1. Rough Carpentry

- a. Any necessary wood framing, blocking, furring, etc. shall be fire treated.
- b. Provide sheet metal backing at sill to 6-in above the floor.
- c. Standards: AWPA P49, AWPA M2 and AWPA U1.

### 2. Plastic-Laminate-Clad Architectural Cabinets

- a. All plastic laminated tops and shelves shall be minimum 1-in thick and edge banded.
- b. All cabinetry shall be designed and constructed to meet or exceed, the latest AWI Quality Standards, Custom grade or better. The University requires the following upgrades to the AWI Quality Standards:
  - i. No composite materials (particle board, fiber board, Masonite, OSB, etc.) shall be allowed within 4-in of the finish floor in laboratories, classrooms, restrooms, janitorial closets, or any area where water may be present. Specify pressure treated lumber, exterior grade plywood, or lumber rated by AWI for exterior use.
  - ii. All interior joints in cabinets where sinks will be installed shall be caulked.
  - iii. The front bottom edge of countertops and aprons where sinks are installed shall be edged in accordance with one of the following requirements:
    - a. The countertop shall have a raised no-drip bullnose edge flush with the front apron.
    - b. The countertop shall have a 1.5-in self-edge projecting .75-in beyond the face of the apron.
    - c. The countertop shall have a bullnose edge flush with the face of the apron.
    - d. Cabinets shall be designed and fabricated to meet the following \_\_\_\_\_
    - e. additional criteria (for laboratory countertops cabinets, see Appendix B – Laboratory Design Requirements)
      - i. Include allowances in the base cabinet to allow for minor vertical adjustments.
      - ii. Material selection shall be based on the intended use. Sinks shall be in accordance with 3.3 Q (3).
      - iii. Individual components shall be as follows:
        - Wood cabinets are acceptable for bio-safety less than level 3. Melamine or plastic laminate is acceptable.
        - Door fronts shall be edge banded on all four sides and sealed with a durable finish for easy clean-ability.
        - Consider “Sustainable Building Products” in the design and fabrication of cabinets. The A/E is expected to evaluate the possibility of such products and submit recommendations to the University Project Manager.

## M. Openings

### 1. Metal Doors and Frames

- a. General - DFCM Standards

### 2. Wood Doors

- a. Wood Doors: Solid core doors faced with minimum of 1/16-in veneer finish are recommended. No wood doors to be used as exterior doors.
- b. Kick plates for doors in heavy traffic areas. This is to include classroom doors.
- c. Standards: Architectural Woodwork Institute (AWI/AWS).

### 3. Plastic Doors

- a. Not permitted.

### 4. Coiling Doors and Grilles

- a. All roll-up fire doors shall be motorized and have automatic self-closing closing device or holder-release mechanism and governor unit complying with NFPA 80 and an easily tested and reset release mechanism. Testing for manually operated doors shall allow resetting by opening the door without

- re-tensioning the counterbalancing mechanism. Release mechanism for motor- operated doors shall allow testing without mechanical release of the door. Automatic-closing device shall be designed for activation by the following:
- b. Building fire-detection, smoke-detection, and -alarm systems.
  - c. Limit Switches: Equip each motorized door with adjustable switches interlocked with motor controls and set to automatically stop door at fully opened and fully closed positions.
  - d. Obstruction Device
    - i. External entrapment device consisting of indicated automatic safety sensor capable of protecting full width of door opening. For non-fire-rated doors, activation of device immediately stops and reverses downward door travel. For fire-rated doors, activation delays closing.
  - e. All motorized roll up doors must have safety bar or motion sensor device to prevent door from closing on vehicles, equipment or persons.
  - f. Detection Devices: External entrapment protection consisting of indicated automatic safety sensor capable of protecting full width of door opening. For non-fire-rated doors, activation of device immediately stops and reverses downward door travel. For fire-rated doors, activation delays closing.
5. Door Hardware
- a. Hospital Projects – Reference current standards by coordinating with Project Manager
  - b. General:
    - i. See attached **Appendix C for Security Systems Standards**, which covers expectations and best practices for software and hardware installation, maintenance, or decommissioning of Access Control Security Management System and CCTV Video Management Systems. This includes CCure.
    - ii. In-Person Confirmation of Install
      - a. Pre-Install Confirmation: Required for all trades involved in installing door hardware. Including, but not limited to: Hardware Installers, Electricians, Integrators and General Contractors. Meeting shall be conducted by a Vendor Representative. Owner shall be invited. The best time for this meeting is after frames have arrived and a hardware installer has been selected, but no later than two weeks before arrival of door hardware onsite.
      - b. Post-Install Confirmation: The purpose of this inspection is to verify that products have been installed according to the manufacturer's instructions. This shall be performed by a Vendor Representative. This shall be conducted near the date of substantial completion.
    - iii. Fire-Rated Door Assemblies
      - a. Where fire-rated door assemblies are indicated, provide door hardware rated for use in assemblies complying with NFPA 80 that are listed and labeled by a qualified testing agency, for fire-protection ratings indicated, based on testing at positive pressure according to NFPA 252 or UL 10C, unless otherwise indicated.
    - iv. Smoke- and Draft-Control Door Assemblies
      - a. Where smoke- and draft-control door assemblies are required, provide door hardware that meets requirements of assemblies tested according to UL 1784 and installed in compliance with NFPA 105.
  - c. Provide lock sets as follows:
    - i. Mortise Locks: BHMA A156.13; Security Grade 1.
    - ii. Ensure that all provided locks are repairable.
    - iii. Rigid function for custodial closets and mechanical rooms with 2-3/4 backset.
    - iv. DO NOT key restrooms.
  - d. Electronic Locks
    - i. For interior doors in existing buildings without the CCure system, and where central monitoring by the University Public safety department is not needed, Dorma Kaba hardware with key bypass entry system will be installed. The system is to be operated, managed and maintained solely by the requesting department.

- ii. ii. All electronic locking systems shall comply with current specifications provided by the University's Alarm Committee. Upon request, the University will loan the A/E a confidential copy of the U of U Alarm Committee Approved Alarm Equipment document for use in the room security design.
- iii. Mortise:
  - a. Schlage L9000 Series.
  - b. Sargent 8200 Series.
  - c. BEST 40H Series.
- iv. Cylindrical:
  - a. Schlage ND Series.
  - b. Sargent 30-10X Line Series.
- e. Cylinder Locks
  - i. High-Security Lock Cylinders: BHMA A156.30; Grade 1 (ALCA ABLOY PROTEC2). Doors with cylindrical locks are to be specified with heavy duty Schlage or prior approved equal. As a minimum standard, specified locks are to conform to Schlage "standard 6 pin cylinders". Smaller formats are not acceptable.
    - a. If an interchangeable core is needed, full-size Schlage IC/LARGE FORMAT IC. This is for all exit devices and keyable mullions.
  - ii. Panic bars shall be specified on exterior doors where a narrow type device is necessary. All panic bars shall be rim type with removable mullions on double doors. May have a 99/9849 33/3547A concealed vertical exit device. When handle is installed on the outside portion of the door, must have handles bolted through.
    - a. Von Duprin 35/33 Series
    - b. Von Duprin 98/99 Series.
    - c. Sargent - PE80/80 Series.
    - d. Best Precision 2000 Series.
  - iii. On all new buildings, or on large remodel projects that require a large number of new locksets, the locksets are to be provided without cylinders or blanks. The University will furnish and install the cylinders in the locksets and provide the keys. Facilities Management will schedule and fund the installation of the keys and cylinders through the University Project Manager.
    - a. Finish.
      - Match existing finish on remodeling projects.
    - b. Door Closers
      - Door closers shall not be located so that they are exposed to the weather. This is intended to reduce or eliminate the effect of water, snow, ice, salt and freeze upheaval on the door.
  - iv. All steel doors 18-gauge or less must have backing plates to support mounting of door closer or door closer must be installed with thru bolts.
    - a. All control devices on automatic doors, such as pneumatic operators must be accessible with not more than an 8-ft ladder.
    - b. Exterior Doors shall be LCN 9500 Series. ASSA ABLOY SW200 Series. Any substitution must be approved by The U

## N. Finishes

1. Where doors that swing into an adjacent wall there must be a backing plate or fire treated wood blocking installed between studs to support sheet rock at the location where the door handles meet the wall to prevent damage and allow better mounting for wall mounted door stops.
2. Confirm components/equipment prior to painting. Valves, venturi valves, equipment nameplates, etc. shall not be painted.
3. External duct wrap is not permitted on painted duct. Use internal lining or none if permitted by code and condensation will not be an issue.

## O. Specialties

1. Toilet, Bath and Laundry Accessories

- a. Infant Changing Stations
  - i. A fold down diaper changing station shall be installed at either a unisex toilet room or in one each of the main floor men's and women's toilet rooms.
- b. Products for Accessories specified above:
  - ii. Subject to compliance with requirements, provide toilet accessories by one of the following:
    - a. American Specialties, Inc.
    - b. Bobrick Washroom Equipment, Inc. (c) Bradley Corporation.

**P. Furnishings**

1. Interior Recycling Bins
  - a. Reference current standard for campus and hospital disposal and recycling programs. See recycling guidelines on waste.utah.edu for Main Campus and coordinate with University Project Manager for hospital projects.

**Q. Elevators**

1. Specify removable full-height bumper blankets for wall protection in elevators primarily intended for freight, supplies, equipment, etc.
2. See 3.11 F (35) for special requirements regarding elevator phones and phone panels, elevator communications connections (traveling cable), access panels, conduit, emergency service lines, etc.
3. See 3.1.J for information on directing "call" buttons.

### 3.4 Structural

#### A. Concrete

1. Warranty: Provide additional two-year written guarantee commencing on the date of substantial completion to promptly remove and/or repair defective concrete (pitting, spalling, cracking, honeycombing, etc.).
2. Concrete Strengths & Testing: Provide minimum compressive strength measured at 28 days of 3000 psi for foundations, stem walls, piers, miscellaneous interior walls, etc., and 4000 psi minimum for all exterior flatwork, ramps, curbs, gutters catch basins, concrete pavements, interior floor slabs, elevated slabs, shear walls and columns. DFCM allows shear wall and columns to be specified in excess of 4000 psi. Specify pre-cast concrete with a minimum strength of 5000 psi.
3. Cement Types: Comply with the recommendations of the Geotechnical report. DFCM requires one of these types: Type I or Type II (both low alkali) and Type V. In southern Utah, usually select Type V. In other parts of the state select Type I or Type II (low alkali).
4. Concrete Mix: Provide low alkali cement for all concrete in direct contact with earth. Specify water/cement ratios in accordance with ACI 318. Specify number of bags of cement per/yard in accordance with C150. Provide admixtures complying with the requirements of ASTM C260 for air entrained concrete. Do not use "IA", "IIA", etc. For frost resistant concrete, the following minimum air contents are required for concrete in direct contact with soils or exposed to severe salting: for 3/4" maximum aggregate size per C33, provide air content per ASTM C260 of 6-1/2%+ 1-1/2%; for 1", provide 6%+ 1- 1/2%; for 1-1/2", provide 5-1/2"+1%. Water cement ratios shall be limited to 0.50. (excluding grout mixes) The slump of all concrete shall be limited to 4" unless plasticizers are used. A maximum of 10% fly ash is allowed.
5. Testing: DFCM shall pay for testing, unless other procedures are specified. The frequency and minimum numbers of test cylinders shall be as outlined in the IBC, however at least three test cylinders must be taken from each pour related to a structural member. The intent is to not to do testing on concrete for items such as curb, gutter, sidewalk, mow strips, light pole bases, etc. Concrete testing shall not be required where allowed by the currently adopted building code.
6. Reinforcement: Reinforce all concrete with conventional rebar or welded wire fabric. Slabs on grade supporting less than 400 psf uniform loads and no rack loads may be un- reinforced. The sub-base for all un-reinforced slabs must be uniformly compacted with on-site observation and per requirements specified in the project specifications.
7. Reinforcing steel shall be minimum grade 60; fy=60 ksi.

### 3.5 Electrical

The latest adopted edition of the following Codes and Standards are to be considered a minimum requirement for Section 3.6. Where items contained in this section are in conflict with any of the following codes or standards, the more stringent requirement shall apply: National Electrical Code – NEC; International Building Code – IBC; International Energy Conservation Code; Illuminating Engineering Society of North America – IESNA Handbook; UL 96A; NFPA 780; Utah State Fire Marshal’s Rules R710; National Fire Alarm Code – NFPA 72; and Agency/Institution Design Standards (comply with the latest edition of the design standards of the project agency or institution. If conflicts exist between DFCM and these design standards, obtain written clarification from representatives of DFCM and the agency/institution).

#### A. Lighting

1. All lighting shall meet or exceed the current energy code for lighting power density, control requirements, and other requirements. All lighting shall utilize the most efficient fixtures available to meet the project requirements and budget. Incandescent lighting shall generally not be used, but may be used with the approval of the DFCM representative in the following applications: theaters/stages, television studios, and art galleries. However, in these applications, LED lighting shall be strongly considered. Exterior Lighting shall be LED unless approved by the DFCM Director. Refer to Section 5.0 for additional requirements on lighting energy requirements.
2. Light Pollution Reduction: Use full cut-off outdoor lighting fixtures for luminaries with more than 3,000 lumens and locate so that the maximum candela value falls within the property. Provide shielding or controlled distribution for any luminaries within a distance of 2.25 times its mounting height from the property boundary so that minimal light from the luminaire illuminates past the property boundary. Interior lighting shall be positioned so that the maximum candela value does not fall outside the interior space, such as out through a window).
3. Lighting Fixtures. Provide lenses that will not yellow due to exposure to sunlight or to the light sources in the fixture. When acrylic diffusers are specified, provide 100% virgin acrylic. Provide electronic ballast suitable for the load type, energy savings, and starting temperatures required. Provide program start ballasts if available for the lamp type. Connect equipment grounding conductor to fixture housing. Provide 10% spare lamps, diffusers, or glass for each light fixture type with not less than one for less than 10 lighting fixtures.
4. Interior Lighting: Provide T-8 lamps in fluorescent fixtures, except for areas requiring special lighting. Dimming of fluorescent fixtures should be avoided. Consideration shall be given to LED lighting for most applications. Provide independent safety-wires attached to structure in compliance with seismic requirements. For recessed fixtures that are removable, locate outlet box with 3’ of steel flexible conduit to the fixture to aid in removing and relocating fixture.
5. Exterior Lighting: ~~Exterior Lighting shall be LED unless approved by the DFCM Director. Provide break way fuses for all phase conductors for all outside pole mounted lighting fixtures. Provide a shorting fuse insert for neutral fuse holder. Do not use common neutral multi-wire circuits for this type of lighting.~~
  - a. UofU Outdoor Lighting System Standards and Specifications are provided in Appendix D.
6. Reflected Ceiling Plan Coordination: Coordinate the lighting fixture with the reflected ceiling plan for suspended, lay-in, and surface-mounted fixtures. Recessed lighting fixtures in acoustical tile ceiling shall be located centered on a single tile.
7. Lighting Fixture Supports: Provide swivel bases for stems supporting lighting fixtures which exceed 12” in length.
8. ~~HID Sources: Use metal halide sources. Provide Pulse Start Metal Halide lamps and electronic ballasts. Where High Pressure Sodium sources are approved, use auto-regulating ballasts.~~
9. LED Sources: Individual LEDs shall be tested in compliance with IES LM-79-08, and rated life shall be as determined by IES LM-80-08 and IES TM-21-11. The complete reports shall be available if

requested. Specify high-CRI (85 or higher) sources. CRI (Ra) shall be based on CIE/IES definition using 8 color criteria. Driver and LED modules shall operate without measurable flicker below 25 kHz. Provide high power factor drivers (>.90). LED modules and drivers shall be replaceable in the field.

**B. Raceways to 600 V**

1. Raceways, Fittings, and Boxes. Provide steel raceway, fitting, and box system for all wiring, except that plastic conduit (minimum schedule 40) may be installed underground and aluminum cable trays may be installed for communications cabling. For steel raceway when installed in contact with soil, provide rigid or IMC PVC coated or wrapped raceways, fittings, etc. Provide steel raceways for penetrating structural elements (minimum 6" each side) and rigid steel conduit (PVC coated or wrapped) for bends greater than 30 degrees. Provide minimum ½" raceways except communications raceways shall be 1" minimum. Larger sizes may be required depending on users' cabling requirements. Provide flexible steel conduit (minimum ½") in short lengths where movement, vibration, misalignment, or cramped quarters exist. Provide insulated throat or equal type plastic bushings for box connections. Provide liquid-tight flexible conduit with approved moisture-tight fittings for wet, humid, corrosive, or oily locations. Provide a minimum 18" liquid-tight flexible conduit at each motor.
2. Electrical Supports: All raceways, boxes, and conductors shall be supported independently from all other electrical or mechanical systems, directly from building structure by a listed supporting device. Provide outlet boxes with rigid support using metal bar hangers between studs.
3. Equipment Pads. Provide concrete pads a minimum of 6" beyond the dimensions of the equipment. Extend equipment pad a minimum of 4" above finished floor or grade.
4. Future Raceways: Provide five capped spare ¾" conduits from each section of a flush-mounted branch panel board into the ceiling and floor space. If the floor space is not accessible, provide an additional ¾" conduit from each section of a branch panel board into the ceiling. Provide 200-lb. nylon pull cord in all empty conduit, then cap raceway using a blank cover similar to adjacent wiring device covers.
5. Underground Raceway Identification and Installation: Provide direct buried conduit in an area outside a building not less than 24" deep, with magnetic "yellow warning" ribbon 12" directly above and 6" below finished grade measured from the top of the conduit or duct bank.
6. Do not provide the following, unless approved by the DFCM Director: exposed cable wiring; other raceways systems (electrical non-metallic tubing, aluminum conduit, die cast fittings, or steel cable trays).
7. Do not route conduit runs on or above the structural roof deck, unless approved by U of U Roofing Asset Manager.

**C. Conductors (INSIDE BUILDINGS)**

1. Provide copper conductors for all wiring in sizes not less than #12 AWG.
2. Aluminum conductors may be considered for feeders and services in sizes #1/0 and larger where approved by the DFCM Director and the user/agency of the project.
3. Size conductors such that total voltage drop on feeders and branch circuits will not be greater than 5%.
4. Metal Clad Cable. Type MC Cable is allowed only when concealed in ceilings or walls. MC Cable must be protected from physical damage and supported directly from the building or structure by use of a listed support. MC Cable home runs are not allowed. Home runs must be in conduit ~~from the electrical panel or cabinet to the first junction or pull box~~ from the electrical panel to a junction box where the first device is physically located. MC Cable Used for Fire Alarm System Signaling or Initiation Circuits must have an overall outer coating of red.
  - a. MC cable is not allowed for circuit runs in mechanical rooms, labs, hallways, or corridors.
  - b. MC cable is not allowed to be exposed in hallways and corridors.
5. Non-metallic sheathed cable may be used only for residential single or multi-family housing unless approved by the DFCM Director.

6. Do not provide the following unless approved by the DFCM Director: exposed cable wiring; splices in panel board, switchboard enclosures, or in conduit bodies.
7. Required conductor identification and coloring:
  - a. All conductors #6 AWG and smaller shall feature colored jacketing from end to end. No taped ends are allowed.
  - b. All three-phase systems shall feature the appropriate jacket coloring. Refer to the table below:

<u>CONDUCTOR</u>	<u>208Y/120V System</u>	<u>480Y/277V System</u>
<u>Phase A</u>	<u>Black</u>	<u>Brown</u>
<u>Phase B</u>	<u>Red</u>	<u>Orange</u>
<u>Phase C</u>	<u>Blue</u>	<u>Yellow</u>
<u>Shared/Single Neutral</u>	<u>White</u>	<u>Gray</u>
<u>Ground</u>	<u>Green</u>	<u>Green</u>

**D. Grounding:** Provide a separate green grounding conductor enclosed with phase conductors in all raceways on the load side of the service entrance.

**E. Medium Voltage**

1. Medium Voltage Conductors: Provide copper conductors with copper tape shields and EPR insulation and copper neutral in Medium Voltage Duct banks; or, in utility tunnels or other areas without public access, provide armored cable or rigid conduit. Comply, as a minimum, with the installation requirements for Medium Voltage Cable standard NECA 600-2003. Perform Hi-Pot test after terminations have been made, but before connections have been made to buses or apparatus. Perform continuity tests of all cables after entire installation and terminations have been completed. If a cable fails to perform, replace faulty cable and retest. All tests will be recorded and submitted with O&M manuals at project conclusion.
2. Medium Voltage Duct Banks. For above-ground or interior of buildings in non-public areas, provide rigid galvanized conduit or armored cable marked with red HIGH VOLTAGE. For underground, exterior applications, or public areas, provide concrete encased duct banks (red dye) with raceways in multi-les of two and a minimum of one spare conduit (with polypropylene pull wire) per feeder. Provide rigid metal conduit for the first 10 feet or duct bank from a facility or manhole. Provide minimum 4" raceway.
3. Lighting Protection: Provide lightning (surge) arresters for medium voltage transformers and switchgear located above ground outside.
4. See Appendix E – Campus Utility Design Standards for University of Utah Medium-Voltage Infrastructure requirements.

**F. Motor Controllers**

1. Provide NEMA rated magnetic motor controllers with thermal overload relays for each phase.
2. Variable Frequency Drives: Provide variable frequency drives suitable for the application, factory pre-wired with integral disconnect, input filter, and integral ventilation. For interior location VFDs, size ventilation for ambient temperature of 32 degrees F. to 90 degrees F. Avoid outdoor location mounted VFDs; but, if required, provide ventilation for ambient temperatures from -30 degrees F. to 120 degrees F. Fault current rating shall be sized based upon the fault current analysis of the nearest upstream overcurrent device. Include factory startup and tune to optimize life of motor.
3. Provide a manual bypass of the VFD as part of controller where motor redundancy is not provided. For fan motor applications, coordinate with mechanical engineer to determine if a bypass should be provided.
  - i. Bypass operation is not required where a minimum of 75% of the design flow rate may be obtained with the operation of the remaining VFD drives.

**G. Electrical Distribution (INSIDE BUILDINGS)**

1. Overcurrent and Ground Fault Protection: Set overcurrent and ground fault protection based upon Fault Current Protection and Coordination Study prepared by a licensed engineer. Submit study with O&M manuals.
  2. Arc Flash Analysis: For new construction and where main panel size exceeds 400 amps, provide an Arc Flash Assessment in accordance with NFPA 70E. Specify labels to be provided at each panel indicating incident energy and arch flash category level.
  3. Transformers: Provide transformers with copper or aluminum conductors. Provide transformer taps of 4 taps – 2.5% above normal and 2 taps – 2.5% below normal. Adjust voltage output to obtain the proper value at the main disconnect.
    - a. See Appendix E – Campus Utility Design Standards for University of Utah Medium-Voltage Infrastructure requirements.
  4. Metering: Provide secondary digital metering (including demand monitoring) at the main distribution panel(s) in each facility. For secondary digital metering of services of 800 Amps or greater, include Harmonic monitoring and an option for building automation or remote monitoring.
    - a. Ensure meters are integrated per University of Utah Sustainability & Energy group’s system, SkySpark. See Metering Guidelines posted on University of Utah’s UFacilities website.
  5. Utility Metering: Comply with serving utility’s regulations, if applicable. Comply with utility’s metering requirements. Include cost assessed by serving utility.
  6. Switchboards and Panel Boards: Provide bus hardware installed on the bus for future over-current devices of not less than 25% minimum. Provide over-current devices in the same sequence as shown on the panel schedules or one-line diagrams.
  7. Panel Boards. Provide listed panel board construction for all branch panels and circuit breaker distribution panels. Load Centers and plug in circuit breakers may be used only in Residential Single and Multi-family residences unless approved by the DFCM Director. Key all panel boards alike and provide three keys.
  8. Circuit Breakers: Provide one-, two, or three-pole over-current devices with common handle (not field modifiable).
- H. Power Quality:** The A/E shall design for power quality by following ~~either~~ the performance- based requirements ~~for the prescriptive-based requirements~~ as indicated below.
1. Performance Approach
    - a. The A/E shall include as a basis of design, an evaluation of potential Harmonic Risks to the Electrical Distribution System and provide a plan to mitigate these risks. The Power Quality Plan shall be approved by the DFCM representative. Power Quality Testing may be performed by the DFCM after the facility is occupied to determine the effectiveness of the Power Quality Mitigation approach.
      - ~~i. The Plan shall address each of the items listed in the Prescriptive Approach below.~~
      - ii. In no case shall the voltage harmonic distortion be greater than 3% THD at the building’s main service or feeder panel, and at other points in the system where sensitive loads may be adversely affected by harmonic distortion.
      - iii. Electrical Distribution System components shall be sized for and/or mitigate the anticipated current harmonic distortion produced by the loads on the system.

The effects of the approach on the overall energy efficiency of the building shall be considered.
  2. Prescriptive Approach
    - a. Electrical Services

- ~~i. Services of 300 KVA or larger shall be 277/480 volt at the Service Main Disconnecting means except for those proven to be unnecessary and approved by the DFCM Director.~~
- ii. Harmonic producing (nonlinear) loads such as lighting, VFDs, UPSs and computer rooms shall be separated or grouped as far as reasonably cost effective.
- iii. All panels fed from a step down transformer with 120/208V 3-phase/4- wire secondary shall have 200% neutral feeders.
- iv. All multi-wire branch circuits shall have dedicated neutrals or oversized shared neutrals that are at least one trade size larger than the phase conductors. Circuits with shared neutral conductors shall have multi- pole breakers per the NEC.
- v. Provide 277 volt lighting wherever there is a 277/480 volt wye service available.

Existing Electrical Services. Power Quality Testing should be performed prior to the Upgrade, Addition, or Alternation of any of the following Electrical Components or Systems, VFDs, UPSs, Step down Transformers and Generators. It shall be determined from this testing the proper equipment and method to be used that will insure that the existing system will not be adversely affected by the work to be performed. Power Quality Testing should be performed after completion to determine the effectiveness of the material and methods used.

- b. Power Factor. All new Construction or Upgrade of existing Electrical Services shall meet the minimum requirement of 95% and maximum of 98% Power Factor. The DFCM representative shall approve the method and layout of Power Factor Correction Capacitors prior to installation.
- c. Step down Transformers
  - i. All step down transformers shall be Energy Star NEMA TPI K rated or HMT with 200% neutral capability, unless proven unnecessary and approved by the DFCM representative. The K rating shall be as determined by Manufacturer recommendations for the equipment they serve.
  - ii. All step down transformers feeding computer rooms or areas subject to high non-linear loads shall be fed from a Harmonic Mitigating Transformer with 200% neutral.
- d. Variable Frequency Drives. For motors 15 hp and larger, provide a minimum power quality performance of 12% current THD and 3% voltage THD measured at the VFD input terminals. This shall be accomplished by using Harmonic filters or a minimum of 12 pulse drive that will comply with the power quality performance requirements. For motors less than 15 hp, provide AC Line Reactors and/or DC link chokes with a minimum of 3% impedance. Provide output filtering if the motor is located more than 50 feet from the drive.
- e. Lighting. Electronic Ballasts shall have <20% THD for 277 volt lighting systems and <10% THD for 120 volt lighting systems. In existing buildings where high Harmonic Currents are present, provide <10% THD ballasts.  
Generators. For new construction, a service that is to be backed up by a generator shall be designed to have no more than 12% current THD or 3% voltage THD when measured at the point where the generator connects to the system, while loads are running on generator. For existing services to be backed up by a generator, power quality testing shall be performed to determine that there is not more than 12% current THD or 3% voltage THD and that there is not a leading power factor. If there is, it shall be corrected prior to bringing the generator on line.
- f. Uninterruptible Power Supplies. Provide a minimum power quality performance of 12% current THD and 3% voltage THD measured at the UPS input terminals. Provide filtering if necessary.
- g. Transient Voltage Suppression System. TVSS shall be provided for the main service of each facility with services greater than 200 amps. A second level of TVSS shall be provided for panels serving primarily computer or non-linear loads.

### 3. Miscellaneous Electrical

- a. Lightning Protection. If the risk analysis performed per HFPA 780 or UL 96A exceeds moderate risk, provide a lightning protection system. Minimum qualifications required: LPI-certified installer, designer, and inspector. Obtain a UL Master Label of LPI Label for the facility.
- b. Generator Fuel Tank Size. When generators are provided, size fuel tank to comply with whichever is greater, the needs of the facility or a minimum of 24 hours of operation at full load capacity.

- c. Hazardous Classifications. Coordinate with the State Fire Marshal hazardous classifications and requirements, including class, division, and group requirements.
  - d. Electrical Penetrations: All mechanical or electrical penetrations of the exterior envelope must be sealed air tight to the air barrier of the exterior wall assembly. If the building does not have an air barrier then the penetrations must be sealed air tight to the existing exterior sheathing and cladding in order to prevent excess air leakage.
    - i. [See DFCM Roofing Requirements for additional guidelines on roofing penetrations.](#)
4. Structured Cabling
- a. Coordinate structured cabling requirements with the IT departments of DFCM, the institution, and the user groups.
  - b. Test all structured cabling systems to demonstrate compliance with TIA/EIA standards for the category of system selected. Include warranty and the test results in the Project Resource Manual.
5. Fire Alarm
- a. Provide addressable fire alarm systems as required by State Fire Marshal’s Rules R710. The installation shall comply with the State Fire Marshal’s Rules R710 and NFPA 72.
  - b. For DFCM-managed buildings, specify non-proprietary manufacturers. Examples of approved types are: Fire-Lite and Silent Knight. All other manufacturers shall be approved by the DFCM Director.
  - c. For institutional buildings, comply with the requirements of the institution.
  - d. Install class “A” looped systems or as approved by the Fire Marshal.
  - e. Fire alarm wiring shall be installed in conduit except as identified in 3.5(c)(4)
  - f. Do not use the following components unless approved by the DFCM Director: other manufacturers, zoned fire alarm panels, ionization smoke detectors.
6. Miscellaneous Systems: Coordinate requirements for other systems such as security, CCTV, audio/visual, etc. with DFCM, the institution, and user groups.
- a. [See Appendix C – Security System Standards for UofU requirements. Building Lockdown Switch information is included in Section 4.1.10 of Appendix C.](#)
  - b. [See Appendix I – UIT Design Standards Supplement for UofU IT requirements.](#)

**I. [Equipment Labeling](#)**

- 1. [Provide permanently engraved nameplate labels/tags for the master nameplate, for each manhole, duct bank, all distribution equipment, devices, etc., listed below as well as all other similar equipment. Other electrical sections in this supplement may have additional labeling requirements. Each label shall include the arc flash hazard class based upon NFPA 70 E, where applicable.](#)
- 2. [Plastic lamacoid nameplates shall be three-ply plastic, 1/16-inch thick. Letters shall be formed by engraving into the outer colored ply, exposing the white or black center- ply. Lettering shall be a minimum of 5/8-inch high.](#)

<u>Label Type</u>	<u>Outer Ply</u>	<u>Lettering Color</u>
<u>Master Nameplate</u>	<u>Black</u>	<u>White</u>
<u>Normal Power</u>	<u>Black</u>	<u>White</u>
<u>Emergency Power</u>	<u>Red</u>	<u>White</u>
<u>UPS Power</u>	<u>Blue</u>	<u>White</u>
<u>Medium Voltage</u>	<u>Yellow</u>	<u>Black</u>

### 3.6 Mechanical - General

#### A. Standards

1. The latest editions of publications and standards listed here are intended as guidelines for design. They are mandatory only where referenced as such in the text of this chapter or in applicable codes. The list is not meant to restrict the use of additional guides or standards. When publications and standards are referenced as mandatory, any recommended practices or features shall be considered required.
  - a. Most recent adopted version of International Code Council
  - b. ASHRAE: Handbook of Fundamentals.
  - c. ASHRAE: Handbook of HVAC Applications.
  - d. ASHRAE: Handbook of HVAC Systems and Equipment.
  - e. ASHRAE: Standard 15: Safety Code for Mechanical Refrigeration.
  - f. ASHRAE: Standard 52: Gravimetric and Dust-Spot Procedures for Testing Air- Cleaning Devices Used in General Ventilation for Removing Particulate Matter.
  - g. ASHRAE: Standard 55: Thermal Environmental Conditions for Human Occupancy.
  - h. ASHRAE: Standard 62: Ventilation for Acceptable Indoor Air Quality.
  - i. ASHRAE: Standard 90.1: Energy Standard for Buildings Except Low-Rise Residential Buildings.
  - j. ASHRAE: Standard 100: Energy Conservation in Existing Buildings.
  - k. ASHRAE: Standard 105: Standard Method of Measuring and Expressing Building Energy Performance.
  - l. ASHRAE: Standard 111: Practices for Measurement, Testing, Adjusting and Balancing of Building HVAC Systems.
  - m. ASHRAE: Standard 113: Method of Testing for Room Air Diffusion
  - n. ASHRAE: Standard 114: Energy Management Control Systems Instrumentation.
  - o. ASHRAE: Standard 135: BACnet: A Data Communication Protocol for Building Automation and Control Networks.
  - p. ASHRAE: Standard 202: Commissioning Process for Buildings and Systems
  - q. ASHRAE: Guideline #4: Preparation of Operating and Maintenance Documentation for Building Systems.
  - r. American National Standards Association: ANSI Z 223.1.
  - s. National Fuel Gas Code Standard 54.
  - t. American Society of Mechanical Engineers: ASME Manuals.
  - u. American Society of Plumbing Engineers: ASPE Data Books.
  - v. Sheet Metal and Air Conditioning Contractors' National Association, Inc. (SMACNA):
  - w. ASHRAE HVAC System Duct Design.
  - x. SMACNA HVAC Duct Construction Standards: Metal and Flexible.  
SMACNA HVAC Air Duct Leakage Test Manual.
  - y. SMACNA Fire, Smoke and Radiation Damper Installation Guide for HVAC Systems.
  - z. Seismic Restraint Manual Guidelines for Mechanical Systems.
  - aa. NFPA Standard 96. [Standard for Ventilation Control and Fire Protection of Commercial Cooking Operations.](#)
  - bb. ASTM A53: Standard Specification for Pipe, Steel, Black and Hot-Dipped, Zinc-Coated, Welded and Seamless
  - cc. ASTM A74: Standard Specification for Cast Iron Soil Pipe and Fittings
  - dd. ASTM A106/: Standard Specification for Seamless Carbon Steel Pipe for High-Temperature Service
  - ee. ASTM A197: Standard Specification for Cupola Malleable Iron
  - ff. ASTM A234: Standard Specification for Piping Fittings of Wrought Carbon Steel and Alloy Steel for Moderate and High Temperature Service
  - gg. ASTM A888: Standard Specification for Hubless Cast Iron Soil Pipe and Fittings for Sanitary and Storm Drain, Waste, and Vent Piping Applications
  - hh. ASTM B32: Standard Specification for Solder Metal
  - ii. ASTM B88: Standard Specification for Seamless Copper Water Tube

- jj. ASTM C564: Standard Specification for Rubber Gaskets for Cast Iron Soil Pipe and Fittings
- kk. ASTM C1540: Standard Specification for Heavy Duty Shielded Couplings Joining Hubless Cast Iron Soil Pipe and Fittings
- ll. ASTM D1784: Standard Specification for Rigid Poly(Vinyl Chloride) (PVC) Compounds and Chlorinated Poly(Vinyl Chloride) (CPVC) Compounds
- mm. ASTM D2444: Standard Test Method for Determination of the Impact Resistance of Thermoplastic Pipe and Fittings by Means of a Tup (Falling Weight)
- nn. ASTM D2661: Standard Specification for Acrylonitrile-Butadiene-Styrene (ABS) Schedule 40 Plastic Drain, Waste, and Vent Pipe and Fittings
- oo. ASTM D2665: Standard Specification for Poly(Vinyl Chloride) (PVC) Plastic Drain, Waste, and Vent Pipe and Fittings
- pp. ASTM D3034: Standard Specification for Type PSM Poly(Vinyl Chloride) (PVC) Sewer Pipe and Fittings
- qq. ASTM D3212: Standard Specification for Joints for Drain and Sewer Plastic Pipes Using Flexible Elastomeric Seals
- rr. ASTM E336: Standard Test Method for Measurement of Airborne Sound Attenuation between Rooms in Buildings
- ss. ASTM E779: Standard Test Method for Determining Air Leakage Rate by Fan Pressurization
- tt. ASTM F876: Standard Specification for Crosslinked Polyethylene (PEX) Tubing
- uu. ASTM F877: Standard Specification for Crosslinked Polyethylene (PEX) Hot- and Cold-Water Distribution Systems
- vv. [ASHRAE Guideline 36: High-Performance Sequences of Operation for HVAC Systems.](#)
- ww. [ANSI/ASME A13.1: Scheme for the identification of Piping Systems.](#)
- xx. All applicable regulations and requirements of local utility companies having jurisdiction.
  - i. [Provide verification the cited Standards or Guidelines have been complied with.](#)

## B. Criteria

1. Design Conditions
  - a. Outdoor air design criteria is from weather data tabulated in the latest edition of the ASHRAE Handbook of Fundamentals.
    - i. Heating design conditions: 99 percent column heating dry bulb temperature.
    - ii. Cooling design conditions for sensible, latent and ventilation load calculations: 1 percent column dry bulb temperature, with its mean coincident wet bulb temperatures
    - iii. Cooling tower selection, and dehumidification load: 1 percent dew point, with its mean coincident dry bulb temperature.
  - b. Occupancy:
    - i. Determine occupant density (persons/ft<sup>2</sup>) from the occupancy schedule of the Program.
    - ii. If this information is not available, use the occupancy density values in ASHRAE 62.1.
    - iii. For dining areas, auditoriums, and other high occupancy spaces, base occupancy densities on the number of available seats.  
Base sensible and latent loads per person on the latest edition of the ASHRAE Handbook of Fundamentals.
  - c. [Site Elevation](#)
    - i. [Select equipment to account for site elevation of 4,750 feet \(1,500 meters\) above sea level. Indicate equipment sea level capacity in the Contract Drawing Equipment Schedules.](#)
2. Load Calculation Software Requirements
  - a. Perform HVAC load calculations with a computer-based program using the latest ASHRAE Handbook of Fundamentals Heat Balance (HB) Method, Radiant Time Series (RTS) Method, or Transfer Function Method (TFM).  
The program must be capable of calculating each zone's peak heating and cooling loads as well as the whole-building simultaneous peak load.
  - b. The program must calculate solar gains through fenestration, internal gains from occupants, including latent heat for cooling purposes, internal gains from lighting and equipment, outside air

- loads (sensible and latent) from ventilation and infiltration, and heat and moisture gains or losses through fenestration, walls, floors, and roofs.
- c. Calculate the heating load without credit for occupants and internal gains.
  - d. Do not include safety factors in the HVAC load calculations unless specifically asked for in the Program.
3. Temperature
    - a. Design for indoor setpoints specified in the Program.
    - b. Ensure control of dry bulb temperature range, allowing for seasonal and unoccupied set point adjustment.
    - c. Control surface temperatures surrounding the occupants to limit the detrimental effects of radiant temperature asymmetry. Use passive methods such as better R- values in materials, and active methods such as delivery of heating and cooling media (air, water, electricity, refrigerant) to offset undesirable surface temperatures.
  4. Humidity Control
    - a. Unless specific control ranges are required by the Program to protect materials or processes, humidity control is neither required nor encouraged
  5. Air Movement
    - a. Occupant comfort: Design to deliver air at less than 30 fpm air speed in heating and 50 fpm air speed in cooling at the occupied level.
    - b. Stratification: Reference ASHRAE 55 for allowable vertical air temperature stratification.  
Airflow noise: Design to meet space and occupant noise level criteria as specified in the Program and or Section Noise Control below.
  6. Building Pressure
    - a. Manage the flow rates of building outdoor air, exhaust air and relief air by the HVAC equipment, reset as determined by the pressure differential of ground floor's exterior space with the outdoor, to achieve 0.02" - 0.05" wc positive building pressure when occupied.
    - b. Maintain positive building pressure when occupied, when outside dew point is higher than 47°F when unoccupied, and/or when specific space humidity control requirements must be maintained.
  7. Ventilation
    - a. Design ventilation rates to comply with ASHRAE Standard 62.1, latest edition, using the Ventilation Rate Procedure
    - b. Provide devices to measure and control minimum outdoor air flow for all variable air volume systems. Provide means for the outdoor air flow rate to be reported to the building DDC system. Comply with all the technical requirements of Section 5.0 HPBS.
  8. HVAC Noise Control
    - a. Design all systems so that space RC is equal to or less than those listed in ASHRAE Applications, Noise and Vibration Control Chapter, Design Guidelines for HVAC-Related Background Sound in Rooms
    - b. Confirm design sound levels are achieved through field measurements in accordance with ASTM E336 "Standard Test Method for Measurement of Airborne Sound Attenuation between Rooms in Buildings"
    - c. Design exhaust systems with appropriate noise mitigation to limit the transfer of exhaust fan noises to the surrounding areas. Provide documentation within the basis of design narrative that identifies the design noise level at areas surrounding the building.
  9. Redundancy
    - a. Provide for continuous operation through redundancy and/or modularization for facilities greater than 30,000 sf or which have critical functions or critical care residents.

- b. The loss of one half or less of the design cooling or heating system for the entire facility shall be tolerated temporarily in the event of equipment failure for: heat pumps, boilers, refrigeration machinery (excluding cooling towers), and condensate pumps.
- c. Redundancy requirements listed above are a recommended minimum; however, individual project requirements shall be consulted to based on project and function.

10. Low-Load Operating Conditions (Shoulder seasons)

- a. Design mechanical systems to be capable of stable operation at 10% of peak load capacity while maintaining space temperature requirements without equipment cycling that is outside of the equipment manufacturer's design and operating recommendations or that will shorten equipment life.

C. High Performance Building System

- 1. Reference High Performance Building System requirements

D. Operability and Maintainability

- 1. Locate mechanical rooms to take advantage of ductwork and piping proximities to major loads.
- 2. Locate all mechanical equipment within the building or on the property in areas not subject to flooding and 5 feet above the 100-year flood plain.
- 3. Accessible for Maintenance
  - a. Install equipment so that it can be safely and easily maintained and inspected.
  - b. Comply with OSHA and other access requirements (step height, reach length, railing and catwalks).
  - c. Comply with requirements for mechanical room sizes and manufacturer's recommended clearances around installed equipment.
  - d. Provide stair access to equipment installed on roof.
  - e. Provide disassembly access for all valves, piping, and equipment.  
Do not locate equipment, panels, damper motors, or other elements more than three feet above a ceiling where access is required with a ladder. Provide walkways and /or catwalks for equipment above these heights.
- 4. Provide means such as overhead rails or structure for attaching winches, lifts, etc. for temporary lifting and support for removal of heavy and /or large parts.
- 5. Simple/Understandable to Operate
  - a. Design the HVAC system design to minimize the need for overly complex control systems.
  - b. Clearly describe and comprehensively document the sequence of operation for the control systems in Operator's manuals, as-built documents, and by posting as-build documents within the control panels.
  - c. Use ASHRAE Guideline 36 "High-Performance Sequences of Operation for HVAC Systems" as a guideline to develop the sequences of operation for the control systems.
- 6. Operations
  - a. Select equipment components, spare parts, and materials so that they are readily available and repairable by local technicians. Avoid special order and/or long lead items when other options are available.
- 7. Provide refrigerant pressure relief piping for refrigerant evaporator coils located near heating coils, pressure relief devices, and fusible plugs, sized and routed per the ASHRAE Standard 15 "Safety Code for Mechanical Refrigeration."
- 8. Where start-up strainers are used and replaced with specified strainers prior to test and balancing, require the Contractor to place each removed start-up strainer near the pump or Y strainer it served for inspection by the University of Utah Facility Operations staff.
- 9. Require the Contractor to provide minimum of 14 days notification to the University Project Manager of major equipment items being ready for factory witness tests if required by the Program.
- 10. Equipment, Pipe, and Duct Identification Specifications Required

- a. Require the Contractor to provide the required identification of all fire suppression, plumbing, and HVAC equipment to include automatic temperature control equipment and sensors, and associated distribution systems. Label all electrical switches and starters for mechanical equipment.
  - i. Specify equipment labels be minimum 1/8” thick plastic, black face with white engraved lettering minimum 3/16” high, and attached securely. If an adhesive is used, it shall be specified to be suitable for the substrate on which it is mounted and withstand the environmental conditions, to include vibration, in which it is to be subjected during normal operations.
    - a. All labels associated with high temperature piping and equipment, and in high temperature equipment rooms shall be as required in the valve section below.
  - ii. Equipment nameplates shall include the following minimum information:
    - a. Record drawing identification.
    - b. Capacity specified at designed operating conditions.
    - c. Actual capacity as balanced at site operating conditions.
    - d. Area or zone served.
  - iii. Provide brass tags for all valves regardless of size, at least 1 inch by 3 inches in size and 0.051 inches thick. Provide engraved lettering on the tag at least 1/8” high. Separately identify each valve on the record drawings using a unique number with the valve tag matching that number. Include the following minimum information.
    - a. Record drawing identification.
    - b. Normal position.
    - c. Duty.
    - d. Area / system served.
    - e. Valve type.
  - iv. For heating water valves, steam valves, and all valves located on the secondary (low pressure) side of HTW heat exchangers, include the following information.
    - a. Manufacturer.
    - b. Size.
    - c. Grade.
    - d. Pressure-temperature service rating.
  - v. Require the Contractor connect valve tags to valve stems using steel rings.
- b. Require the Contractor to comply with ANSI/ASME A13.1 “Scheme for the Identification of Piping Systems” for marking accessible ductwork and piping. Although ANSI/ASME A13.1 does not cover ductwork, apply the same requirements for ductwork.
- c. Require the Contractor to apply the following Table for piping and ductwork labeling using the ANSI/ASME A13.1 color definitions.

<u>MEDIUM IN PIPE OR DUCT</u>	<u>BACKGROUN D COLOR</u>	<u>IDENTIFYING LETTERING</u>	<u>LETTERI NG COLOR</u>
<u>COMPRESSED AIR</u>			
<u>Lab Service</u>	<u>Gray</u>	<u>Compressed Air</u>	<u>Black</u>
<u>Automatic Controls</u>	<u>Gray</u>	<u>Control Air</u>	<u>Black</u>
<u>COMPRESSED GAS</u>			
<u>Hydrogen</u>	<u>Brown</u>	<u>Hydrogen</u>	<u>Black</u>
<u>Natural Gas</u>	<u>Brown</u>	<u>Natural Gas</u>	<u>Safety Yellow</u>
<u>Nitrogen</u>	<u>Gray</u>	<u>Nitrogen</u>	<u>Black</u>
<u>Oxygen</u>	<u>Brown</u>	<u>Oxygen</u>	<u>Black</u>
<u>REFRIGERANT</u>			
<u>Freon</u>	<u>Black</u>	<u>Freon</u>	<u>White</u>
<u>STEAM – LOW PRESSURE (0 – 15 PSIG) (NOTE: NO BANDS FOR LOW P R E S S U R E )</u>			

<u>Steam – Low Pressure</u>	<u>Safety Orange</u>	<u>Low-Press. Steam</u>	<u>Black</u>
<b>STEAM – HIGH PRESSURE (OVER 15 PSIG) (NOTE: TWO BLACK BANDS REQUIRED FOR HIGH PRESSURE)</b>			
<u>Steam – High Pressure</u>	<u>Safety Orange</u>	<u>Hi-Press. Steam</u>	<u>White</u>
<b>VACUUM</b>			
<u>MEDIUM IN PIPE OR DUCT</u>	<u>BACKGROUND COLOR</u>	<u>IDENTIFYING LETTERING</u>	<u>LETTERING COLOR</u>
<u>Vacuum</u>	<u>Gray</u>	<u>Vacuum</u>	<u>Black</u>
<b>WATER **NOTE: DIRECTIONAL ARROWS ARE REQUIRED ON HTW PIPING.</b>			
<u>Boiler Blow-Off</u>	<u>Safety Yellow</u>	<u>Blow-Off Water</u>	<u>Black</u>
<u>Chilled Water Supply</u>	<u>Safety Blue</u>	<u>Chilled Water Supply</u>	<u>White</u>
<u>Chilled Water Return</u>	<u>Safety Blue</u>	<u>Chilled Water Return</u>	<u>White</u>
<u>Condenser Water Supply</u>	<u>Safety Blue</u>	<u>Cooling Water Supply</u>	<u>White</u>
<u>Condenser Water Return</u>	<u>Safety Blue</u>	<u>Cooling Water Return</u>	<u>Black</u>
<u>Condensate Return (Note: One white band is required for Steam Condensate Return.)</u>	<u>Safety Orange</u>	<u>Condensate Return</u>	<u>Black</u>
<u>Cold Water (Potable)</u>	<u>Safety Green</u>	<u>Domestic Cold Water</u>	<u>White</u>
<u>Non Potable</u>	<u>Safety Green</u>	<u>Unsafe Water</u>	<u>Black</u>
<u>Domestic Hot Water (Potable)</u>	<u>Safety Green</u>	<u>Domestic Hot Water</u>	<u>White</u>
<u>Domestic Hot Water Return</u>	<u>Safety Green</u>	<u>Domestic Hot Water Return</u>	<u>White</u>
<u>Fire Protection Water</u>	<u>Safety Red</u>	<u>Fire Protection</u>	<u>White</u>
<u>Glycol Solution</u>	<u>Safety Purple</u>	<u>Glycol Solution</u>	<u>White</u>
<u>High Temperature Supply</u>	<u>Safety Yellow**</u>	<u>High Temperature Water Supply</u>	<u>Black</u>
<u>High Temperature Return</u>	<u>Safety Yellow**</u>	<u>High Temperature Water Return</u>	<u>Black</u>
<u>Secondary Heating Water Supply</u>	<u>Brown</u>	<u>Heating Water Supply</u>	<u>White</u>
<u>Secondary Heating Water Return</u>	<u>Brown</u>	<u>Heating Water Return</u>	<u>White</u>
<u>Deionized</u>	<u>Safety Green</u>	<u>Deionized Water</u>	<u>White</u>
<u>Distilled Water</u>	<u>Safety Green</u>	<u>Distilled Water</u>	<u>White</u>
<u>Reverse Osmosis</u>	<u>Safety Green</u>	<u>Rev. Osmosis Water</u>	<u>White</u>
<u>Softened</u>	<u>Safety Green</u>	<u>Softened Water</u>	<u>Black</u>
<u>Roof Drain</u>	<u>Safety Green</u>	<u>Roof Drain</u>	<u>White</u>
<u>System Make-Up</u>	<u>Safety Green</u>	<u>Make-Up Water</u>	<u>White</u>
<u>Treated Water</u>	<u>Safety Green</u>	<u>Treated Water</u>	<u>Black</u>
<b>WASTE</b>			
<u>Acid-Resistant</u>	<u>(unpainted)</u>	<u>Acid Waste</u>	<u>White</u>

<u>Building Waste</u>	<u>(unpainted) or Black</u>	<u>Waste</u>	<u>White</u>
<u>MEDIUM IN PIPE OR DUCT</u>	<u>BACKGROUND COLOR</u>	<u>IDENTIFYING LETTERING</u>	<u>LETTERING COLOR</u>
<u>Polluted Water</u>	<u>Black</u>	<u>Polluted</u>	<u>Safety Yellow</u>
<u>ALL EQUIPMENT OR PIPING LOCATED OUTSIDE BUILDINGS</u>			
<u>All Equipment or Piping Located Outside Buildings</u>	<u>Brown</u>	<u>---</u>	<u>---</u>

11. Equipment Access for Maintenance

- a. In addition to Code compliance, for elevated equipment, design an appropriate platform for equipment service and maintenance, to include platform space in front of appliance components that require periodic service or replacement.
- b. Provide a cross over ladder design for all ductwork and piping at walking level that must be crossed for equipment inspection, service, or maintenance.

E. Alterations in Existing Buildings and Historic Structures

1. Design HVAC systems to avoid affecting other systems and historic finishes, elements, and spaces.
2. Place exterior equipment where it is not visible. Recess equipment from the edge of the roof to minimize visibility of the equipment from grade. Alternatively, explore creating a vault for easier access to large mechanical equipment. If equipment cannot be concealed, specify equipment housings in a color that will blend with the historic face. As a last resort, enclose equipment in screening designed to blend visually with the facade.
  - a. Pending review by U of U Carpentry, existing equipment curbs for non-ducted equipment may be re-purposed for new installations, assuming structural considerations are addressed. New metal caps must be provided, with no penetrations through top surface of cap. (Attach equipment to curb via Uni-strut or similar, bearing on cap and attached through sides of cap.) Electrical and line-set details routed through roof as per DFCM Roofing program standard details.
3. Locate equipment with particular care for weight and vibration on older building materials.
4. Retain original plaster ceilings in significant spaces, such as lobbies and corridors, to the extent possible and modified only as necessary to accommodate horizontal distribution. Use soffits and false beams where necessary to minimize the alteration of overall ceiling heights. In buildings containing ornamental or inaccessible ceilings, route piping and ductwork in furred wall space or exposed in the occupied building area. Consider exposed ducts in historic industrial buildings with open plan, tall ceiling, and high window spaces suited to flexible grid/flexible density treatments.
5. If new vertical air distribution risers are required, locate adjacent to existing shafts.
6. Select system types, components, and placement to minimize the alteration of significant spaces. In previously altered spaces, design systems to allow historic surfaces, ceiling heights, and configurations to be restored.
7. Retain decorative elements of historic systems such as ornamental grilles and radiators where possible.
8. Retain and enhance the performance of the original type of system where a new one cannot be totally concealed or would adversely affect historic spaces or features. For example, adapt existing radiators with modern heating and cooling units, rather than adding another type of system that would require the addition of new ceilings or other non-original elements.
9. To the greatest extent possible, ensure that space is available to maintain and replace equipment without damaging significant features and select components that can be installed without dismantling window or door openings.
10. Select temperature and humidity conditions that do not cause deterioration of building materials.
11. Locate and construct all mechanical rooms so that equipment can be replaced and repaired with standard, normally available equipment, without special or custom built dimensional requirements, and minimal disassembly.
12. Avoid locations requiring difficult lifting and / or heavy crane requirements that will interfere with occupant activities in an occupied building.

13. Where existing steam, heating, or cooling systems must be extended or revised, verify the existing demand and generation capacity before adding new equipment loads. Determine and detail the connection point locations for all new equipment loads.
  - a. Conduct a thorough analysis and understanding of the impact on the original system of the modifications or extensions. Ensure the design includes adjustments to the original building systems, including record (as-built) drawings, with modified values shown, to return all adjacent systems to the original working capacities. If original condition cannot be determined, then as part of the design fee, include the services of balancing technicians to determine the actual status of the existing systems.
  - b. Verify with Facilities as to the current set points of the system. Do not rely solely on record drawings for system set points. UFacilities will provide to Design Team, which may be requested through the University Project Manager.
  - c. Where the modification or extension will be connected to an existing piping system, identify the age of the piping at the tie-in point. If the piping system is more than 20 years old, replace the piping back to the equipment room from which it originates. If this presents undue hardship on the project scope/budget, an exception may only be granted in writing through the approval of a Variance Request submitted to the University Project Manager.
  - d. Any HVAC system that is modified shall be rebalanced and recommissioned. See DFCM Design Requirements Section 5 for additional requirements. If modification/extension serves more than the area under the scope of work, require the entire area served be re-balanced and recommissioned. If this presents undue hardship on the project scope/budget, an exception may be granted in writing through an approval of a Variance Request submitted to the University Project Manager.

#### **F. High Temperature Water (HTW) in Buildings**

1. For HTW design in Tunnels, see **Appendix E – Campus Utility Design Standards**
2. Design Parameters
  - a. Upper Zone: served by HTW generated in Building 302.
    - i. System operating pressure is 460 psig.
    - ii. System operating temperature is 390 deg F.
  - b. Lower Zone: served by HTW generated in Building 303.
    - i. System operating pressure is 460 psig.
    - ii. System operating temperature is 435 deg F.
  - c. Shell-and-Tube Generators, Minimum Approach Temperature
    - i. Determine minimum approach temperature by the following.
      - a. HTW return temp – secondary HW supply temp
    - ii. HTW Steam Generator Minimum Approach Temperature:
      - a. 10 deg F for 45 psig to 100 psig steam operating pressure.
      - b. 15 deg F for 44 psig and lower steam operating pressure.
    - iii. HTW water-to-water converters including domestic water heaters:
      - a. 15 deg F.
  - d. Maximum Allowable Pressure Drop
    - i. For all HTW shell-and-tube generators, the maximum allowable pressure drop is 20 psig calculated from the HTW building entry to the HTW building leaving the building, to include all pressure drop through the HTW piping, equipment, and controls.
  - e. Ratings
    - i. Specify piping, equipment and valves pressure and temperature ratings based on requirements listed in this Annex.
3. Detailed Calculations
  - a. During the design process, provide detailed calculations of the HTW extension into the building to the University Project Manager for review and approval by Facilities Management.
    - i. Ensure the calculations reflect the inside diameter of the pipe being specified, i.e. if specifying Schedule 80 (heavy wall) steel pipe, ensure the calculations reflect the smaller interior pipe diameter as compared to Schedule 40 steel pipe.

- b. Update the Fathom model to reflect the change to the HTW system load due to the Project.
- 4. HTW Equipment Rooms
  - a. See structural design requirements in Section 3.4. of the University of Utah supplement to the DFCM design requirements.
  - b. Design room(s) containing HTW systems to quickly drain water away from the room.
  - c. Heat Exchangers
    - i. Design room so that there is adequate clearance between potentially hot surfaces to allow equipment servicing to protect technicians.
      - a. Ensure manual isolation valve placement allows safe servicing access to operate the valve(s).
    - ii. Avoid designing housekeeping pads under the HTW shell-and-tube generator. Hydraulic lifts are used to remove heat exchanger heads. Provide a minimum of 3 feet clearance at the floor behind the heads for proper access.
    - iii. Within the design, provide proper access to remove shell-and-tube generator tube bundles for maintenance and servicing.
      - a. For mechanical rooms with multiple generators, the access must be within the mechanical room since the remaining generators will likely be kept in service.
      - b. For mechanical rooms with a single generator, access for tube bundle pull may be made through the HTW generator room door, as long as the door opens into an adjacent mechanical space.
  - d. For all HTW connections to the shell-and-tube generator, include vent and drain connections, and provide double isolation valves in series for HTW supply, HTW return, vent piping, and drain piping.
  - e. Route shell-and-tube generator safety valve piping to an acceptable open air receiver. Design receiver to prevent splashing of water coming from the safety valve when the safety valve is open. Route HTW drain piping to this same receiver. Provide for gravity drain from the HTW drain piping.
    - i. Ensure code requirements are maintained within the design with respect to discharge from the receiver into the building drainage system.
      - a. An after cooler may be required to decrease the receiver water discharge temperature before discharging to the drainage system.
- 5. Piping Systems
  - a. Design piping to conform to the most current version of ASM B31.1 “Power Piping”.
  - b. Use Fanning or other equally acceptable formulae to calculate flow, velocity, and resistance in water piping.
  - c. Specify all valves as pneumatic operated, normally closed with spring return.
    - i. Specify manual isolation valves as gate valves meeting ANSI Class 600 requirements.
      - a. Provide double valves in series at all HTW connections to shell-and-tube converters, to include drain and vent piping.
  - d. Minimize Shock
    - i. If the length of HTW piping between the control and the shell-and tube generator exceeds 20 feet, provide in the design a bypass line near the converter to allow HTW circulation which serves to keep the idle HTW consistently hot thereby preventing start-up shock.
  - e. HTW Piping Vent Lines
    - i. Provide details showing vent valves at the highest point of the HTW system inside the building.
    - ii. Provide details showing vent valves at the high point of each shell-and-tube converter at the high point of the HTW supply and return piping serving the converter.
    - iii. Provide details showing vent and drain piping at HTW connections at the shell-and-tube header.
    - iv. Specify multiturn gate valves, with dual valves on each vent line.
    - v. Minimum vent size is NPS 1 inch.
  - f. Steam Generator Blowdown Heat Recovery
    - i. Design generators with heat recovery on the blowdown line. Use the recovered heat to temper the makeup water to the generator to avoid shocking the generator.
  - g. Emergency Isolation Valve at Building Supply



### 3.7 Plumbing

#### A. Domestic Water Supply Systems

##### 1. Cold Water Service

- a. Cold water service consists of a pressurized piping distribution system incorporating a separate supply line from the tap in the existing outside water main to the equipment area inside the building.
- b. Refer to Section 3 for information on the University's water distribution system requirements. The University's domestic water pressure generally exceeds 80 psig.

##### 2. Materials

###### a. Exterior Buried

- i. Copper tube: ASTM B88 Type K with wrought copper and bronze solder joint fittings in conformance with ANSI B16.22 or cast bronze solder joint fittings in conformance with ANSI B16.18.
- ii. Ductile Iron Pipe Fittings and Joints, Class 150, with mechanical joints and fittings with set screw retaining glands conforming to ANSI/AWWA C110/A21.10 and ANSI/AWWA C111/A21.11.
- iii. Polyvinylchloride Water Pipe, Fittings, and Joints conforming with NSF Standards #14 and #61 and cell classification 12454-A or -B per ASTM D-1784.

(001) Solvent cement to be low volatile organic compound (VOC) to meet South Coast Air Quality Management District (SCAQMD) Rule #1168.

###### b. Interior Buried

- i. ASTM B88 Type K annealed (soft) copper water tube with 95% tin 5% antimony solder joints using wrought fittings.
- ii. No joints below grade.

###### c. Interior Tube Supported by Hangers and Clamps

- i. ASTM B88 Type L hard drawn copper tube with wrought copper fittings and couplers up to 6", cast brass or bronze fittings and couplers for sizes 6" and larger.
- ii. Joints:
  - (001) 95-5 Class SnSb solder
  - (002) Roll-grooved couplers and fittings for 3" and larger tube.
- iii. Copper ProPress fittings conforming to material requirements of ASME B16.18 or ASME B16.22 and performance criteria of IAPMO PS 117
- iv. Crosslinked polyethylene tubing in accordance with ASTM F 876 and ASTM F 877.

###### d. Penetrations

- i. All mechanical or electrical penetrations of the exterior envelope must be sealed air tight to the air barrier of the exterior wall assembly. If the building does not have an air barrier then the penetrations must be sealed air tight to the existing exterior sheathing and cladding in order to prevent excess air leakage.
- ii. See DFCM Roofing Requirements for additional guidelines on roofing penetrations.

##### 3. Soil Cover

- a. For outside services greater than 6000 HDD, provide minimum cover of 48" or preferred cover of 60". In no instance shall the minimum depth be less than the frost line.
- b. For outside services less than 6000 HDD: Provide minimum cover of 36" or preferred cover of 48".

4. Meters

- a. Meter water service with compound meter(s) furnished by the local department of public works.
  - i. See Metering Guidelines posted on University of Utah's UFacilities website.
- b. Provide double check valves on incoming service.
- c. Provide remote reading capability of meters.
- d. Sub-meter irrigation systems.
  - ii. See Appendix F – Site, Landscape, and Irrigation Design Requirements. Meter installations shall comply with HB121.
- e. Campus Water Meters.
  - iii. Install meter in the main mechanical room or within easy access of mechanical spaces.
    - (003) If conditions do not permit inside installation, provide meter box outside.
    - (004) The meter box shall be 52" x 81" x 71" high with a concrete base under the meter, but the rest of the floor shall be gravel. Top shall have recessed eyes. Top to be poured separate so it can be moved off with a crane and the eyes shall be left large enough to insert a chain by which it can be lifted. Cover to have a 24 inch locking meter lid in center. Position meter so it can be read without personnel entering the vault. Water meter indicator shall be the totalize type reading directly in gallons of water. Water meter shall be installed with valves on both sides so meter can be removed and a bypass line installed. Sleeve around pipes passing through walls of meter box.
- f. Where fire sprinklers are installed, connect the fire main ahead of the meter.

5. Gauges

- a. Provide pressure gauges with gauge cocks on each side of equipment and devices which have a pressure drop, such as PRVs, strainers, and heat exchangers.

6. Pressure Regulators

- a. Specify adjustable, diaphragm type, globe style valve.

7. Backflow Prevention

- a. Show location of valves on drawings indicating installation not more than five feet above finished floor for servicing and locate in accessible place, preferably not in an occupied space.
- b. Provide Class 250 strainers, with cast bronze or iron body, threaded ends, solid retainer cap.
- c. Provide ball valves on strainer to allow for draining.

8. Internal distribution to supply domestic cold water to all plumbing fixtures, water heaters and all mechanical make-up water needs.

9. Design distribution system to maintain adequate pressure and flow in all parts of the system under all operating conditions.

10. Use duplex booster pumping system if the water pressure is not adequate to provide sufficient pressure at highest, most remote fixture. Ensure that the water pressure at the fixture is in accordance with the International Plumbing Code.

11. Completely insulate, with vapor barrier, all domestic cold water piping above ceiling and where concealed in walls, or any location where condensation could cause mold growth or damage.

12. Provide water hammer arrestors at every branch to multiple fixtures and on every floor.

13. On existing buildings having plumbing renovations where piping is demolished, designate all demolished piping be removed and capped at an active main or branch to prevent stagnation in an idle branch pipe. Do not leave inactive piping abandoned in-place.

14. Valves

- a. Use ball valves with full opening ports and adequate pressure and temperature rating up to three inches in size, and butterfly valves with wheel and gear operator for 4 inches and larger.
- b. Provide flange valves on sizes 2.5 inch and greater.
- c. Specify valve stem installed horizontal or higher than the valve.
- d. Provide valves near the main with a union for all branch lines of water which supply more than one outlet or unit.
  - i. Provide isolation valves as necessary and provide, as a minimum, valves for each toilet group outside of the toilet room, each floor, and each branch line that is 2" or greater
  - ii. Provide a quarter-turn ball shutoff valve on all water supply lines on the room side of the fixture.
  - iii. Supply lines from the valve shall be 3/8" brass, chrome plated.
  - iv. Provide chases or access panels to access valves, with proper identification on or near panel.
  - v. Water relief valves: Connect water relief valve exhaust or discharge to nearby floor drain. Provide sump in pipe tunnels at each cleanout.
- e. Pressure Reducing Valves
  - i. For building water entry at laboratory and research buildings, provide two full size reduced pressure principal backflow prevention valves pipe in parallel.
  - ii. For building entry at office and classroom buildings, provide one full size and one half size reduced pressure principal backflow prevention valves in parallel.

## B. Hot Water Service

1. Materials and valves: Same as cold water
2. Generate hot water with heaters utilizing natural gas, electricity or steam as an energy source. Support selection by an economic evaluation incorporating first cost, operating costs and life cycle costs in conjunction with the HVAC energy provisions.
  - a. In new construction, do not use high temperature hot water heat exchangers to produce hot water unless high temperature hot water is available all year round.
    - i. Intent is to reduce campus dependency on high temperature hot water during the cooling season.
3. Generate and store domestic hot water at 140°F, and temper to 120°F using a three-way mixing valve, before supplying to all plumbing fixtures.
4. Provide secondary drain pans under water heaters and hot water tanks, piped to the nearest floor drain.
5. Boost supply water temperature from 140°F to 180°F to dishwasher(s).
6. Evaluate heat pump hot water heaters where possible to save energy.
7. Ensure that hot water is available at the furthest fixture from the heating source within 15 seconds of the time of operation.
8. Distribution system consists of a piping system which connects water heater or heaters to all plumbing fixtures as required. Circulation systems or temperature maintenance systems are included.
  - a. Design and balance circulation systems to less than 4 fps velocity to minimize piping erosion.
  - b. Control circulation systems based on water return temperature and building occupancy.
  - c. Monitor domestic hot water supply and return temperatures and circulation pump status by the building automation controls system.
9. Provide water hammer arrestors at every branch to multiple fixtures and on every floor
10. Solar Water Heating
  - a. If lifecycle cost effective based on Program directive or five year ROI, meet at least 30 percent of the hot water demand for each new building or building undergoing a major renovation through the installation and use of solar hot water heaters.
11. Insulate hot water distribution systems per ASHRAE 90.1 and provide all exposed piping with PVC jacketing.
12. Coordinate installation to allow access for maintenance and replacement.

13. Provide combination temperature and pressure relief valve piped to adequate drain.
14. Specify flexible connections and tie-down straps to accommodate movement during seismic events.
15. For buildings being renovated where high temperature hot water heat exchangers are being replaced, replace with heat pump water heaters.
16. Water Conditioning Systems
  - a. All building with hot water for classroom sinks, toilet room lavatories, laboratory sinks, or other uses requiring hot water or where hand washing is being encouraged, provide water softening equipment to serve these locations.
  - b. Design in built-in water totaling meters on the inlet line and on the conditioned water supply line.
    - i. Include a hose bib in close proximity and within eyesight of the installed equipment for mixing and tank filling activities. Include a floor drain near the hose bib when chemicals will be used in the equipment.
  - c. Provide water softening equipment with minimum duplex resin tanks, a single brine tank not exceeding 48 inches in height, and an automatic regeneration system activated by the amount of flow, not by time clock. Include in the design a blow-in salt delivery system.
    - i. Provide water system softening systems Basis of Design on manufacturers GE Osmonics, Pacific Water Incorporated, Water Specialties, or Fluid Treatment Systems.
      - (a) Manufacturers other than the above shall be reviewed and approved by Facilities Management, through the University Project Manager, prior to bid.
  - d. Provide water conditioning equipment for secondary steam and water systems connected to HTW generators and converters, to include the make-up and feed water.
  - e. Other buildings on campus requiring conditioned water other than softened water typically include laboratories and research facilities. These may include deionized water, reverse osmosis water, filtered water, or a combination of these to achieve the proper degree of water chemistry, purity, or polishing. Provide the proper pipe system material required for these services.

### C. Sanitary Waste and Vent System

#### 1. General

- a. Cast iron pipe centrifugally cast service weight (SV) soil pipe with cast iron drainage fittings conforming to ASTM A 74.
- b. Joint materials and systems
  - i. Hub and spigot with neoprene gaskets and lubricant conforming to ASA 021 and ASTM C 564 SV pattern.
  - ii. Cast iron hubless pipe and fittings conforming to ASTM A 888, CISPI 301.
    - (a) Hubless couplings shall conform to ASTM C 1277 for standard and ASTM C 1540 for heavy duty or CISPI 310.
- c. Polyvinylchloride (PVC) sewer pipe and fittings conforming to DR 35, ASTM D3034, bell and spigot type with reinforced rubber ring gasket integral with bell joint, material to meet ASTM D1784, D2444 and joint tightness in accordance with ASTM D3212.
  - i. Solvent cement to be low volatile organic compound (VOC) to meet South Coast Air Quality Management District (SCAQMD) Rule #1168.

#### 2. Buried Pipe

- a. SV hub and spigot cast iron pipe and fittings
- b. No-Hub standard weight cast iron pipe with either M-G couplings or heavy-duty stainless steel shielded couplings. The heavy-duty shielded couplings shall comply with ASTM C1540, with ASTM C564 neoprene gaskets,

#### 3. Interior Pipe Supported By Hangers and Clamps

- a. Hubless cast iron pipe using hubless cast iron soil pipe couplings certified to withstand a minimum of 50 psi internal pressure, or higher if required by application.
  - b. Sump pump discharge shall be Schedule 40 galvanized steel pipe with NPT threaded joints and fittings.
4. Plastic Drain, Waste and Vent Piping
- a. Plastic DWV may be either P.V.C. or A.B.S. as required by code, utilizing drainage pattern fittings.
    - i. P.V.C. (polyvinylchloride) pipe and fittings shall conform to ASTM D2665 with a flame spread rating of 25 or less
    - ii. A.B.S. (acrylonitrile butadiene styrene) pipe and fittings shall conform to ASTM D2661, CS 270 65
  - b. Solvents for plastic piping
    - i. Solvents for plastic piping joints shall be certified to meet SCAQMD Rule #1168/316A. This includes but is not limited to PVC, CPVC, and ABS piping, all grades and sizes.
5. Vent Piping and Fittings
- a. Same as waste piping above.
6. Floor Drains.
- a. Provide floor drains in multi-toilet fixture restrooms, kitchen areas, mechanical equipment rooms, locations where condensate from equipment collects, and parking garages and ramps.
  - b. Single fixture toilet rooms do not require floor drains. For all gender ready multiple-user restroom, provide a floor drain in each enclosed toilet stall and one in the general sink area.
  - c. Provide cast iron body type floor drains with 6 inch diameter nickel-bronze strainers for public toilets, kitchen areas and other public areas.
  - d. Equipment Room Floor Drains
    - i. Trenches with grating covers with bottoms sloped to drain are preferred but not required over multiple floor drains in mechanical equipment rooms and some laboratories
  - e. Parking Garages

Large diameter tractor grates or trench drains inlets when exposed to rainfall.
  - f. Water Still Drains
    - i. Provide Kimax glass to nearest main drain from water still drains or provide glass pipe for the first 20 feet horizontally or to the floor below.
    - ii. Provide cleanout at water still and at main drain line before glass is connected with soil piping
  - g. Provide drains indirectly connected to building drainage system for walk-in refrigerators and other places where food is stored.
  - h. Use deep seal traps or trap seals. Do not use trap primers.
  - i. For indirect drain piping, use Type L hard drawn copper with wrought copper fittings and lead free solder.
7. Sanitary Waste Equipment
- a. Discharge specific drains in kitchen areas into a grease interceptor before connecting into the sanitary sewer in accordance with the requirements of the state health department and local authorities will determine which drains.
  - b. Discharge floor drains and/or trench drains in garage locations into sand/oil interceptors.
8. Automatic Sewage Ejectors
- a. Only use sewage ejectors where gravity drainage is not possible. If they are required, connect only the lowest floors of the building to the sewage ejector; for fixtures on upper floors use gravity flow to the public sewer.

- b. Non-clog, screen less duplex pumps, with each discharge not less than 4 inches in diameter.
  - c. Connect to the emergency power system.
9. Pipe Tunnel Sumps
- a. Provide sump in pipe tunnels at each cleanout.
  - b. Three foot square and four feet deep with grating cover and porous walls.
  - c. Floor drains may be used in lieu of sump if depth of waste line is such that drains may be tied in.
10. Waterproofing Pans
- a. Provide membrane waterproofing pans for shower stalls and custodial floor sinks so they are 100% water tight.
  - b. Provide clamping device which clamps drain to pans.
  - c. Provide a mastic seal between floor drain bottom and lead or membrane so when clamping device is tightened there is a complete seal so no water can get through.
  - d. Do not clog weep holes.
  - e. Test pans by placing test plug in drain and filling with water overnight.
11. Dishwasher Connections
- a. Provide indirect connection for waste on automatic dishwashing machines. Install minimum 3” drain in an accessible location under conveyor table.
12. Cleanouts
- a. Provide cleanouts at base of each vertical rise, each turn in excess of 45 degrees and on straight runs every 50 feet.
13. Horizontal Waste lines:
- a. Provide dedicated minimum 3” horizontal waste lines with adequate cleanouts for garbage disposals and dishwashers.
14. Acid Resisting Waste Systems
- a. See Appendix B - Laboratory Design Requirements.
15. Building Renovations
- a. Remove all drain, waste, and vent piping scheduled for removal or demolition, and provide a cap at the active branch or main. Do not abandon piping in-place.

#### D. Rainwater Drainage System

- 1. Size piping system based upon local rainfall intensity, with minimum pipe size = 3”
- 2. Roof Drains
  - a. Cast iron body type with cast iron high dome grates and membrane clamping rings.
  - b. Provide a separate overflow drain located adjacent to primary roof drain.
  - c. Overflow drains are the same drains as the roof drains except that a damming weir extension is included.
- 3. Rainwater Drainage Equipment.
  - a. Foundation drainage system with perforated drain tile collecting into a sump containing a pumping system as required by the applicable codes shall be provided.
- 4. Drain roof drains to pervious area, or captured for re-use where a re-use system is available.
  - a. Do not allow roof drains to drain into walk areas.
  - b. For indirect roof drains, avoid draining into walk areas.

5. Where draining into walk areas is unavoidable, provide an indirect drain connected sump, with grate, to move the water to the storm drain system

#### E. Plumbing Fixtures

1. In compliance with the International Plumbing Code and local building codes.
2. Apply water conservation technologies to the extent that the technologies are life-cycle cost-effective, based on criteria established in Program, or 5 year ROI
3. Use plumbing products labeled under the EPA WaterSense program.
4. Reference the Architectural Barriers Act Accessibility Standard (ABAAS) for plumbing fixture accessibility clearances, installation, and accessories requirements.
5. Provide all lavatories with open grid strainers.
6. Showers
  - a. Non-scald type shower valve with integral stops.
  - b. Vandal-proof institutional type shower heads with flow adjustment and adjustable head and spray.
  - c. Extend head out from wall so water does not run down wall when valve is turned off.
  - d. Provide watertight shower escutcheon with weep hole in bottom.
7. Drinking Fountains
  - a. Refrigerated type, wall hung drinking fountains with stainless basins.
  - b. Provide removable grid strainer to enable cable-style cleaning without having to dismantle the fountain.
  - c. Provide drinking fountains fitted with water bottle filler, see Section 5.2.6.C.
8. Water Closets (Toilets)
  - a. Flushometer valve type
    - i. Either dual-flush or low-flow type, manually controlled. For single flush, maximum flush volume when determined in accordance with ASME A112.19.2 (1.28 gallon).
    - ii. For dual-flush, effective flush volume determined in accordance with ASME A112.19.14 and USEPA WaterSense Tank-Type High Efficiency Toilet Specification -1.28 gal.
    - iii. Exposed type flush valves with lever operator (no push buttons or floor operators), diaphragm type only.
    - iv. Screwdriver stop valves.
    - v. Concealed flush valves in restrooms subject to vandalism.
  - b. High Efficiency Toilets (HET) Water Closets Tank-Type
    - i. Do not specify unless approved by the Director
    - ii. If used, comply with the performance criteria of the U.S. EPA WaterSense Tank-Type High-Efficiency Toilet Specification.
9. High Efficiency Urinals (HEU)
  - i. Low-flow, flush-type fixtures.
  - ii. Maximum flush volume when determined in accordance with ASME A112.19.2: 0.125 gallon.
  - iii. Sensor valves are acceptable
10. Public Lavatory Faucets
  - a. Use metered-type faucets for lavatories. Maximum water use: 0.25 gallon per metering cycle when tested in accordance with ASME 112.18.1 / CSA B125.1.
11. Emergency Fixtures

- a. Eyewash (0.4 gpm per fountain), face wash (3 gpm each), or shower (20 gpm each) must be tempered immediately at the fixture or group of fixtures within 25 feet to deliver tepid water between 85°F and 100°F, at 30 psi, within 10 seconds, for a minimum period of 15 minutes, and must account for temperature drop across the valve (generally 20°F) at flow.
- b. Provide manual open and close ball valves at each fixture.
- c. Provide accessible fixture isolation valves near each station.
- d. Provide floor drains under emergency showers
- e. Provide Basis of Design fixture manufacturers as Haws, Bradley, or Guardian.

## 12. Faucets and Hose Bibs

- f. Provide non-freeze type hose bibs with shut-off valves for the lines serving the hose bib located inside facility.
- g. Provide faucet with hose attachment and vacuum breaker in each restroom so floor can be washed with clean water.
- h. Provide hose bib with vacuum breaker in mechanical rooms and chiller rooms.
- i. Provide non-freeze hose bib with vacuum breaker near cooling tower.
- j. Provide hose bibs outside building for window washing, walk and area way washdown (generally not more than 150' on center).

## 13. For Service Sinks in Wet Custodial closets, see Section 3.3.H for requirements.

## F. Natural Gas Systems

### 1. Service Entrance.

- a. Protect gas piping entering the building from accidental damage by vehicles, foundation settlement or vibration.
- b. Where practical, the entrance should be above grade and provided with a self-tightening swing joint prior to entering the building.
- c. Do not locate gas piping in unventilated spaces, such as trenches or unventilated shafts, where leaking gas could accumulate and explode.

### 2. Gas Piping within Building Spaces.

- a. Do not route gas piping through confined spaces, such as trenches or unventilated shafts.
- b. Ventilate vertical shafts carrying gas piping
- c. Locate gas meters in a gas meter room.
- d. Use plenum rated fittings for all gas piping inside ceiling spaces.
- e. Vent all diaphragms and regulators in gas piping to outdoors.
- f. Provide seismic bracing for all gas piping within building

### 3. Install regulator/meter sets outside the building at an easily accessible and well ventilated area away from any building air intake.

- a. Do not route gas piping underground downstream of the regulator/meter set.

### 4. Remove all piping scheduled for demolition, with the piping capped at an active branch or main. Do not abandon piping in-place.

## G. Fuel Oil Systems

### 1. Fuel Oil Piping

- a. Schedule 40 black steel or black iron piping. Fittings of the same grade as the pipe material.
- b. Bronze, steel or iron valves, may be screwed, welded, flanged or grooved.
- c. Use double-wall piping with a leak detection system for buried fuel piping.

- d. Use duplex fuel-oil pumps with basket strainers and exterior enclosures for pumping the oil to the fuel burning equipment.
2. Underground Fuel Oil Tanks
  - a. Double wall, non-metallic construction or contained in lined vaults.
  - b. Size for sufficient capacity to provide 48 hours of system operation under emergency conditions (72 hours for remote locations).
  - c. Provide a leak detection system, with monitors and alarms for both
  - d. Provide emergency power to all components of the Fuel Oil Storage system
  - e. Comply with local, State and Federal requirements, as well as EPA 40 CFR 280 and 281.

#### **H. Compressed Air Systems**

1. Specify Type L hard drawn copper with wrought copper solder fittings and lead free solder; or, ASTM A53 Grade A or B, Schedule 40 galvanized steel with 150-lb galvanized malleable iron screwed fittings.
2. For ball valves, see requirements for domestic water applications.
3. Where butterfly valves are used, provide ductile iron body, 200# WOG rating, with bronze disc and Type 304 stainless steel; seat with Buna N rubber.
  - a. Specify valves rated for maximum 180 deg F temperature and capable of tight shut-off at rated pressure without the need for downstream blind flange.
  - b. For valves 5 inch and smaller, specify 10 position locking type levers.
  - c. For valves 6 inch and larger, specify manual gear operators.

#### **I. Vacuum Piping Systems**

1. Design to prevent extraneous liquids in the system and from exiting out through the vacuum hose cocks and into the space.
2. Slope horizontal branch lines minimum 1 in per 40 feet towards the main and enter into the top of the mains.
3. Connect hose cocks into the top of the branch line. Back-to-back hose cocks are not allowed.
4. Only use vertically dropped lines where no other routing method is available, and slope all remaining piping back to the vacuum source.
  - a. If terminal vacuum lines are to drop vertically to terminal outlets, trap such outlets with convenient access and accompanying written instructions describing when and how to clear the trap.
5. Design in a receiver tank placed upstream of any vacuum pump or set of vacuum pumps to prevent liquids or solids from entering the pump.
6. Specify Type L hard drawn copper with wrought copper solder fittings and lead free solder; or, ASTM A53 Grade A or B, Schedule 40 galvanized steel with 150 lb galvanized malleable iron screwed fittings.
7. Specify ball valves as in the domestic water applications Section.
8. Specify butterfly valves as in the HVAC water service section, except specify all sizes are for non-leakage performance to and including 29.9 inches of mercury (Hg) pressure.

### 3.8 HVAC Systems

#### A. Air Distribution Systems

1. Supply air distribution systems are to be fully ducted to the spaces that are served.
2. Coordinate the location of any exhaust or relief air with mechanical air intake systems to avoid short cycling
3. For all gender ready multiple-user restrooms, exhaust openings complying with the requirements of the International Mechanical Code for toilet rooms shall be provided in each stall.
4. Provide dedicated relief air path for all systems which introduce outside air. Exfiltration through the building envelope does not comply with this requirement.
5. Ductwork Materials:
  - a. Provide rectangular and round ductwork from galvanized steel, stainless steel or aluminum.
  - b. Meet or exceed SMACNA and ASHRAE Standard 90.1 requirements for duct construction, installation and leakage.
6. VFD Bypass
  - a. See Section 3.3.F.3 for VFD Bypass requirements.
7. Do not specify the use of fan-powered VAV terminal units.
8. Volume Adjusting Devices
  - a. Provide devices that can be securely locked in place and are accessible for adjustment after construction.
9. Do not provide the following components, unless approved by the Director:
  - a. Duct Lining in the following applications:
    - i. Outside air ducts,
    - ii. Ductwork within 10 feet downstream of any device that adds moisture to the air stream
    - iii. Ductwork exposed to humid air stream above 70% RH such as swimming pool applications.
  - b. Fiberboard ductwork.

#### B. Piping System

1. Materials:
  - a. Steel:
    - i. Pipe:

(001)	2 Inch & Smaller: ASTM A53, Grade A, Schedule 40 black butt weld or continuous welded steel.
(002)	2 1/2 Inch & Larger: ASTM A53, Grade B, Schedule 40 black butt weld or continuous welded steel.
    - ii. Fittings:

(001)	2 Inch & Smaller: ASTM A197, Class 150 black malleable iron screwed. 2 1/2 Inch & Larger: ASTM A234, Steel butt weld, standard weight forged fittings.
-------	---
  - b. Copper:
    - i. Tube:

(001)	Up to 4" inclusive ASTM B88, Type L, hard drawn.
-------	--
    - ii. Fittings:

- (001) ANSI/ASME B16.23 cast brass and/or
      - (002) ANSI/ASME B16.29 solder wrought copper
    - iii. Joints:
      - (001) ASTM B32, solder, Grade 95 TA.
    - iv. ProPress option for copper tubing, fittings, and joints:
      - (001) Conform to material requirements of ASME B16.18, ASME B16.22, and IAPMO PS 117.
      - (002) Joints conform to ASME B16.18, ASME B16.22, and IAPMO PS 117.
  - c. Penetrations:
    - i. All mechanical or electrical penetrations of the exterior envelope must be sealed air tight to the air barrier of the exterior wall assembly. If the building does not have an air barrier then the penetrations must be sealed air tight to the existing exterior sheathing and cladding in order to prevent excess air leakage.
    - ii. See DFCM Roofing Requirements for additional guidelines on roofing penetrations.
2. Underground Pipe
- Comply with ASTM A106.
3. Air Vents
- a. Provide suitable air vents for all heat producing equipment (converters, unit heaters, coils, etc.).
  - b. Provide with manual air vent valves at system high points and drain valves at system low points.
    - i. Furnish suitable provisions, such as access panels, to permit full access to these valves.
    - ii. Manual air vents shall be 3/8" globe valves with 1/4" copper tubing to near floor or to locations where water may be caught in bucket.
    - iii. Drain valves shall be threaded for 3/4" hose connections.
    - iv. Provide water-tight sleeve and caulking around pipe for all piping passing through floors.
4. Valves
- a. Provide valves near the main with a union for all branch lines of water or steam which supply more than one outlet or unit.
  - b. Ball valves with full opening ports and adequate pressure and temperature rating up to 3 inches in size, and butterfly valves with wheel and gear operator for 4 inches and larger.
  - c. Valves 2" and larger on systems greater than 200 degrees F shall be flanged or grooved.
  - d. Provide chases or access panels to access valves. Provide proper identification on or near panel.
  - e. Do not use triple duty valves at loads. Use a shut-off valve, check valve, and balancing valve, if required, in series.
5. Hydronic Flow Control and Balancing Devices
- a. Provide flow control at all major terminal devices to include but not limited to coils, heat exchangers, and HTW converters.
  - b. Specify with marked memory stop, and if handles are provided, to remove the handles and turn them over to the owner after test and balancing has been completed.
  - c. Show on the drawings the location of the flow control devices.
    - i. Require the valve installation such that the flow measuring ports are available for valve maintenance and serving without standing on a ladder.
  - d. Pumps with variable speed drives do not require flow control devices at the pump.
6. Insulation
- a. Insulate piping in compliance with prevailing energy code or the requirements of the High Performance Building Standard, whichever is more stringent.

- b. Provide PVC jacket on all piping exposed to view, and in mechanical rooms
- c. On pipes subject to condensation, use non-permeable insulation of perm rating 0.10, such as cellular glass or preformed composite insulation system.

7. If glycol is used for freeze protection, use propylene glycol. Do not use ethylene glycol.

### C. Steam

#### 1. Motor Operated Steam Valve:

- a. If the existing central plant serving the campus is a steam system, provide a motor operated steam valve for each new building.
- b. Coordinate location with the Agency.
- c. If equipment requires steam when the valve may be closed, connect equipment ahead of motor operated steam valve.

2. Design for gravity flow of condensate in lieu of providing vacuum pumps.

3. Provide tunnels, chases, access doors, or crawl spaces for accessing steam piping. Do not install underground or in split tile

Provide properly dripped steam mains. Provide drip legs ahead of all steam pressure reducing valves and steam coils to ensure clean, dry steam at the valve.

#### 4. Valves

- a. Low pressure steam valves shall have a 200 psi rating and allow renewable seats and discs.
- b. For 100 psi steam line use 250 psi flanges and 300 psi screwed valves.
- c. Provide valves near the main with a union for all branch lines of steam which supply more than one outlet or unit.

#### 5. Piping

- a. 2" and smaller: schedule 80 black steel.
- b. 2-1/2" or larger: schedule 40 black steel for low pressure steam (15 psig or less) and schedule 80 black steel for medium and high pressure steam (greater than 15 psig).
- c. Condensate piping: schedule 80 black steel pipe, including underground return lines.

#### 6. Underground Steam Lines

- a. Use pre-insulated pipe for underground steam lines, materials as noted above, with separate insulated conduits for steam and condensate return piping.

#### 7. Expansion Provisions

- a. Provide expansion loops, swing joints, offsets, etc., for expansion of piping.
- b. Do not use expansion joints except when expansion loops, offsets, swing joints, etc., are not possible due to space constraints.
- c. If expansion joints are provided, provide adequate internal or external guides that are properly supported anchored.  
Do not provide swing joints on main runs; however, swing joints may be installed on risers off the main.

#### 8. Pressure Reducing Stations

- a. Provide pilot-operated valve for pressure reducing stations.
- b. Provide a three valve bypass at all reducing stations with ample clearance to permit normal maintenance and inspection.
- c. Use parallel pressure reducing stations when low demand is expected.
- d. Provide safety relief valves on the low pressure side of regulator stations. Provide discharge piping to facility exterior in a safe location.

For pipes discharging near grade, install pipes into an eight inch concrete tie set upright in the ground (buried) over a gravel base twelve inches deep.

- e. Provide pressure gauges on both the high pressure and low pressure sides of all regulator stations. Locate gauges so they will function when bypass is used.
  - i. Provide gauge cocks and pig-tails.
- 9. Steam Meter
  - a. Refer to section 5.0 HPBS.
- 10. If campus system hot water system is turned off during the summer, provide alternate heating system for equipment requiring a heating source.
- 11. Miscellaneous Requirements
  - a. Provide eccentric reducers when steam piping changes pipe sizes with the flat side on the bottom of the pipe.
  - b. Provide water-tight sleeve and caulking around pipe for all piping passing through floors.
- D. High Temperature Water**
  - 1. Comply with the specific requirements of the high temperature water provider.
    - a. See **Appendix E - Campus Utility Design Standards** for high temperature water (HTW) underground distribution system requirements.
    - b. See **University of Utah Campus HTW System Design Requirements** for piping installed in tunnels, and piping and equipment in building mechanical rooms.
- E. Natural Gas**
  - 1. Seismic gas shut off valve:
    - a. Provide a seismic gas shut off for each natural gas system.
  - 2. Natural Gas Piping
    - a. Weld all concealed natural gas piping if larger than 4".
    - b. Install flexible connections and tie-down straps to accommodate movement during seismic events.
  - 3. Soil cover for outside services: Provide minimum cover of 24" or preferred cover of 36" for gas.
- F. Building Automation**
  - 1. Direct Digital Control:
    - a. For new construction, use DDC with an open BACnet or LonTalk communication protocol in accordance with ASHRAE Standard 135.
    - b. For repair and alteration projects and new additions to existing projects, the following options are permitted:
      - i. Installation of DDC with the BACnet or LonTalk protocol,
      - ii. Integrating the existing system with customized gateways to the BACnet or LonTalk protocol.
      - iii. Pneumatic control as an extension of an existing system, if specifically required by operating personnel
      - iv. If less than 50% of the building controls are affected, use the same controls manufacturer as on the existing building.
    - c. Provide digital metering of electrical, hot water, steam, and chilled water sources to each facility. Refer to section 5.0 HPBS.
    - d. Provide flow metering devices for hot and chilled water heating systems. . Refer to section 5.0 HPBS.
  - 2. Zoning
    - a. Provide as many thermal control zones as is practical, but a minimum:
      - i. Provide one zone per 1,000 ft<sup>2</sup> of internal space.
      - ii. Provide one zone for every three perimeter enclosed offices.

- iii. Provide a separate control zone when a room has more than one external exposure (e.g. corner office).
  - iv. Provide separate control zone for densely occupied spaces such as classrooms, conference rooms.
  - v. Provide separate control zone for unusual occupancy zones such as dining halls, computer room, entryways, etc.
  - vi. For perimeter radiant systems, provide Hydronic piping sub circuits to match the cooling zones.
3. Control Valves
- a. Provide characterized-type ball valves for modulating control valves up to 2-1/2"
  - b. Provide visual position indicators.
  - c. Provide control valves with stem in the vertical position.
  - d. If possible, provide packless valves.
  - e. Pressure-independent control valves are preferred.
    - i. If specifying pressure independent control valves, delete the need for a load balancing valve as well as the valve flow rate test and balance as these are self balancing valves.
4. Dampers
- a. Provide low leakage design of felt or neoprene edges for fresh air, relief, and exhaust air dampers.
  - b. Provide appropriate blade action for the application. Generally, provide opposed blade type for modulating control and parallel blade type dampers for mixing or on-off control.
  - c. Provide controls that close the fresh air dampers on fan shutdown or power failure.
  - d. Provide steel trunnions mounted in bronze sleeve bearing or ball bearings for damper blades. Do not exceed 48 inches in length between damper bearings.
  - e. Provide dampers that close substantially tight and provide substantially the full area of the opening when open.
  - f. Provide substantial bar or channel frames for dampers.
  - g. For rectangular dampers larger than four square feet in area, provide additional corner bracing.
5. Space Temperature Sensors
- a. If system supports DDC monitoring, provide solid state temperature sensors.
  - b. Temperature sensors in corridors, halls, restrooms and other similar unsupervised areas shall be flush mounted aspirating type with stainless steel cover.
  - c. Temperature sensors in public, but supervised areas shall have locking covers with concealed adjustment.
  - d. Temperature sensors in private offices may have exposed adjustments.
  - e. Avoid locating temperature sensors on outside walls or on partitions between offices.
6. Panels
- a. Provide control devices, relays, piping, wiring and terminals in cabinets, except for switches, pilot lights, and push buttons mounted on the door.
  - b. Provide minimum 14 gauge steel or 12 gauge aluminum.
  - c. Equip doors with hinges, latches, and locks
  - d. Secure panels to walls, columns or floors with clearances required by NEC.
  - e. Provide two (2) keys for each panel.
7. Wall Mounted Control Diagrams
- a. Provide plastic laminated copies of all applicable controls diagrams mounted on the wall in each equipment room.
8. Control Wiring
- a. Provide control wiring in raceway complying with the requirements of Section
  - b. Label all control wiring on each end of wire termination points and where passing at intermediate locations passing through walls, in junction / pull boxes. Labels shall match wiring diagrams.

- c. Control wiring shall NOT be spliced.
9. Control System Contract Documents
- a. In general, design HVAC controls systems using ASHRAE Guideline 36, non California requirements. In using this Guideline, revise information in the Guideline as necessary to meet the functional requirements of the Project.
  - b. On the Contract Drawings, provide a control schematic design for each system.
    - i. Include the relative location of sensors and actuators.
    - ii. Include all safety devices such as freezestats and smoke detectors.
    - iii. Provide unique sensor and actuator identifiers.
    - iv. Require the unique sensor, actuator, and device identifier to be used on the controls shop drawings and on the BAS graphics, as well in the test and balance documentation.
    - v. Identify the design value for all set points, and require these values be updated on the Record Documents.
  - c. Provide a Sequence of Operation on the Contract Drawings for each control system schematic. Include:
    - i. General description of the equipment being controlled and operated.
    - ii. The normal (unpowered) position of all actuators.
    - iii. Condition that enables and disables each of the controlled equipment.
    - iv. Condition that energizes and de-energizes the controlled equipment to satisfy the load
    - v. The position of all actuators upon loss of electrical power.
    - vi. A list of monitoring only sensors.
    - vii. Sequence of Operation changes if equipment is used in emergency situations, such as fire alarm notification, smoke control systems, emergency generator operation.
  - d. Where control system components are provided by an entity other than the contracted controls company, include in the Sequence of Operation the operation of the other entity's component(s) to ensure a fluid description of the sequence of operation.
    - i. As an example, the direct evaporative cooling section in an air handling unit may have controls provided by the evaporative cooling section manufacturer. As such, require the contracted controls company to integrate this information in the overall Sequence of Operation.
  - e. Where control/monitoring sensors and actuators not located in mechanical rooms show the actual locations of these devices on the mechanical floor plans.
    - i. Require the Contractor to indicate the actual installed locations on the Record Documents.
  - f. Provide a Control Valve Schedule on the Contract Drawings identifying the valve Cv rating and the valve selection pressure drop through the valve, as well as the valve connection sizes to the piping.

#### G. Chilled Water System

- a. If the peak cooling load is 300 tons or more, provide at least two equally sized chillers at 67 percent of the peak capacity.
- b. Design chilled water system for a minimum 15oF  $\Delta T$ , or higher if feasible
- c. Provide adequate system volume to minimize potential for chiller short-cycling
- d. For water-cooled chillers, design entering condenser water temperature to be 75oF
- e. Provide adequate valving to isolate the offline unit without interruption of service.
- f. Evaluate primary-only pumping.  
Analyze a waterside-economizer cycle during the design of the chiller plant and incorporate in the design if it improves the performance.

#### H. Boiler Plant

- a. If the peak heating load is greater than 500 MBH, provide at least two equally-sized modular boilers sized at 67 percent of peak demand.
- b. Evaluate the use of condensing boilers where feasible.
- c. Evaluate methods to minimize pumping energy through strategies such as high  $\Delta T$ , primary only pumping

- d. Provide boiler backup by redundancy or modularization.
- e. If a power burner is specified, determine the maximum allowable length of positive pressure flue.

**I. Condenser Water System**

1. Provide each chiller with its own matching cooling tower or cell, and condenser and chilled water pump.
2. In the event of multiple cooling towers, provide equalizing lines and automatic control valves to allow individual chiller/cooling tower operation.
3. Use plastic pipe where possible

**J. Roof-Mounted Equipment**

1. Mechanical equipment, except for cooling towers, air-cooled chillers, evaporative condensers, exhaust fans, and packaged rooftop equipment, is not permitted on the roof of the building.  
Provide access to roof-mounted equipment by stairs or freight elevator. Do not use ship's ladders.

**K. Water Treatment System**

1. Design the water treatment for closed and open hydronic systems with consideration of the operational and maintenance needs of all system equipment including such components as boilers, chillers, cooling towers, other heat exchangers, pumps, and piping.
2. Subject to the specific requirements of the components, the performance of water treatment for closed and open systems must include:
  - a. Closed Systems
    - i.  $8.5 < \text{pH} < 10$
    - ii.  $100 \text{ ppm} < \text{alkalinity} < 500 \text{ ppm}$
    - iii.  $\text{TDS} \leq 500 \text{ ppm}$
  - b. Open Systems
    - i.  $7.5 < \text{pH} < 9.5$
    - ii.  $100 \text{ ppm} < \text{alkalinity} < 500 \text{ ppm}$
    - iii. Iron content  $\leq 3 \text{ ppm}$
    - iv. Soluble copper  $\leq 0.2 \text{ ppm}$
    - v.  $\text{TDS} \leq 500 \text{ ppm}$
  - c. The methods used to treat the systems' makeup water must follow the guidelines outlined in ASHRAE Applications Handbook.
3. Provide BACnet or LonTalk self-contained controls for the chemical feed.
4. Provide for one year on-site service by water Treatment Company including supply of chemicals.  
Provide treated water in the heating system until facility is accepted by DFCM.

**L. District Steam Heating**

1. When steam is furnished to the building, convert to hot water with a heat exchanger in the mechanical room near the entrance into the building.
2. Steam heating is discouraged inside the building, other than the conversion of steam to hot water in the mechanical room.
3. Investigate the use of district steam condensate for preheating domestic hot water.
4. Refer to section 5.0 HPBS.

**M. Special Area HVAC Systems**

1. Special areas such as atriums, auditoriums, entrance lobbies and vestibules, cafeterias, mail rooms, loading docks, computer and server rooms, fire pump rooms, BAS control rooms, and fire command centers may require dedicated HVAC systems, separate from all other HVAC in the building, with individual controls to condition these spaces as required.

2. Provide dedicated cooling units to any spaces or processes which require continuous cooling such as telecommunication and main telecommunication rooms, electrical, and server rooms.
3. Provide a separate dedicated air-handling system for each mail room. Airflow must maintain negative pressure in the room relative to adjacent spaces.
4. See Laboratory design requirements in Appendix B – Laboratory Design Requirements.

### 3.9 Automatic Sprinkler Systems

- A. Provide an automatic sprinkler system in buildings when required by State Fire Marshals Rules R710. The Installation shall conform to State Fire Marshals Rule R710 and NFPA 13.
- B. It is desirable that all buildings constructed by the State of Utah be equipped with an automatic sprinkler system to provide added life safety for the occupants and to protect the building from fire loss.
- C. Fire sprinklers shall be considered as an integral component of building design when the availability of water supply and the cost do not make the installation prohibitive.
- D. Secondary structures and small buildings or buildings with low occupant loads may be excluded from this requirement with the approval of the Director.
- E. The design is to include a floor sink at all drains discharging from sprinkler systems, including the inspector's test drains, low point drains and the system auxiliary drain at the building riser. Connect the floor sinks to the nearest sanitary sewer and provide an air gap at the floor sinks.
- F. All pipe systems require Schedule 40 black steel pipe.

### 3.10 Components

#### A. Air Handling Units (AHU)

1. Provide DDC (BACnet or LonTalk) self-contained controls that are capable of being connected to the central BAS. Controller must have a current-sensing device that transmits information to the BAS for calculating the energy consumption of the AHU motor.
2. Additionally, control panel should include:
  - a. fuses,
  - b. high static shut off
  - c. fire shut off
  - d. speed reference control
  - e. fan status
  - f. cfm air flow measurement
3. Provide with mixing boxes on the return side of the AHU.
4. Construction:
  - a. Formed and reinforced, double wall insulated panels, fabricated to allow removal for access to internal parts and components,
  - b. Maximum 1% leakage on the casing.
5. Fans
  - a. It is preferred that fans be direct drive centrifugal with backward inclined, SWSI airfoil wheels
  - b. Be sure wheels are rated for maximum motor speed  
Fans for large, custom, or built up air handler units may be provided with a single, double or fan array type fan system. The fan type should be based on system performance, redundancy, maintenance and efficiency requirements, as well as owner/user preference.

#### B. Outdoor Air Intake Locations

1. Locate outdoor air intakes as high as possible to minimize potential of outdoor air contamination.
2. On buildings more than 40 feet tall, locate intakes a minimum of 40 feet above grade. On buildings less than 40 feet, the locate intakes as high as practical on the roof or on a wall.
3. Duct outdoor air intakes directly to the AHU cabinet. Do not use the equipment room as an outdoor air intake plenum.
4. Locate outdoor intake locations as far away from contaminate sources as possible, and not less than code required minimum. Sources include but are not limited to; generator exhaust, loading docks, vehicle garages and parking lots, sewer vents, exhaust fans, dumpsters, smoke break enclosures, etc.

#### C. Filtration

1. For air handlers exceeding 10,000 cfm, provide pressure differential instrumentation across the filter bank to facilitate maintenance.
2. Provide minimum MERV 8 filters upstream of all cooling coils and other devices with wetted surfaces per Standard 62.1- Section 5.8
3. Provide minimum MERV 13 filters on all ventilation outdoor air intakes where the national standard for PM10 is exceeded
4. Provide minimum MERV 13 filters on all ventilation outdoor air intakes where the national standard for PM2.5 is exceeded
5. Specify that the Contractor replace all filters prior to building occupancy and provide one replacement set of filters for the entire facility.
6. Provide pressure differential sensors across each filter bank. Monitor and alarm through the building automation system.

#### D. Cooling and Heating Coils

1. Locate equipment and other obstructions in the air stream sufficiently downstream of the coil so that they will not come in contact with the water droplet carryover.

2. Cooling coils
  - a. Select cooling coils at or below 500 fpm face velocity.
  - b. Coils with five or fewer rows may have a maximum of 12 fins per inch.
  - c. Coils with six rows or more should not exceed 10 fins per inch.
  - d. Provide stainless steel drain pan, piped to drain
3. Heating coils
  - a. Select heating coils, including reheat coils, at or below 750 fpm face velocity.
  - b. Maintain fluid velocity below 3.5 fps.

#### E. Pumps

1. Provide pressure gauge with gauge cocks as close to pump suction and discharge as possible and avoid pressure drops across valves, strainer, flexible connectors, etc.
2. Provide suitable throttling valves on discharge side of constant speed pumps, such as globe valves, or balancing cocks. Throttling valve shall have set point position indicator and shall not be used for shutoff valve.
3. Provide pot feeder across pump for each closed hydronic system.
4. Variable Speed Pumps:
  - a. Do not install throttling valves on the discharge of a variable speed pump.
  - b. Utilize a venturi to measure water flow rate.
  - c. Variable flow operation intent is to allow the flow control over the full frequency range from minimum flow frequency to maximum flow frequency, with the maximum rated frequency equal to the design flow at maximum load.
  - d. Require the pump system be tested for maximum design flow rate and pressure developed once the pump is installed. If the design flow and pressure developed point occurs at less than 90% of the maximum frequency rating, reprogram the VFD to limit amp draw.
5. Pumps Not Installed On Grade
  - a. For base mounted pumps in mechanical rooms where the floor is elevated above grade, provide a housekeeping pad as well as an isolation base under the pump.

#### F. Boilers

1. Use equal-sized modular boilers for hydronic heating applications. Exception: One smaller “Pony” boiler may be used to meet low load conditions.
2. Install boilers in a mechanical room with all provisions made for breeching, flue stack, and combustion air.
3. The A/E shall coordinate with the University’s Environmental Health & Safety Office for specific University requirements regarding equipment efficiency and compliance with air permits.

#### G. Chillers

1. Acceptable Compressor Range (tons)
  - a. scroll  $\leq$  200 ton
  - b. 100  $\leq$  screw  $\leq$  500 tons
  - c. 200  $\leq$  centrifugal
2. ~~Specify appropriate ASHRAE and ARI Standards and certification.~~

#### H. Accessories

1. Provide air separators and expansion tanks for all closed hydronic systems regardless of piping arrangement.
2. Connect air separators and expansion tanks into piping system on suction side of distribution pump.

#### I. Hot Water Piping and Pumps

1. Materials acceptable for piping systems are stainless steel, black steel, cast iron and copper.

- a. Size fluid velocity at less than 4 fps in Copper piping systems with temperatures above 100°F.
2. For copper piping, brazed, soldered and press-seal (test to 300 psig) fittings are acceptable; grooved or mechanically formed T-type fittings are not acceptable.

**J. Isolation of Piping at Equipment**

1. Provide isolation valves, shutoff valves, bypass circuits, drain valves, flanges, and unions for piping at equipment to facilitate equipment repair and replacement.
2. Equipment requiring isolation includes boilers, chillers, pumps, coils, terminal units, and heat exchangers.
3. Provide valves for zones off vertical risers, including drain valves.

**K. Flexible Pipe Connectors**

1. Fabricate flexible pipe connectors from annular close pitched corrugated and braided stainless steel.
2. Grooved pipe solutions are acceptable. Select gasket materials for each fluid type, including temperature and pressure requirements of each system.
3. Provide flexible connectors at all pumps, chillers, cooling towers, and other rotating equipment. Exception: In-line pumps, if manufacturer recommends against or prohibits.

**L. Meters, Gauges, and Flow Measuring Devices**

1. Provide each piece of mechanical equipment with instrumentation in addition to test ports to verify critical parameters, such as capacity, pressures, temperatures, and flow rates.
2. Calibrate each meter, gauge, and flow measuring device before startup and make provisions for periodic calibration at its location.
3. All the metering devices must be capable of transmitting information to the central BAS for monitoring and control.
4. Refer to section 5.0 HPBS

**M. Unit Heaters**

1. If a unit heater is higher than 10' AFF, use a centrifugal blower (not a propeller fan).
2. Provide all gas or oil unit heater with a 2-stage thermostat. On call for heat, the first stage cycles the fan. The second stage fires the burner.
3. For shop applications with heavy duty or corrosive atmospheres, provide sealed combustion units that bring combustion air from outside the space.

**N. Converters**

1. Provide side inlets and side outlets for all converters.
2. Provide pressure gauges with snubbers on the primary and secondary side of each converter.
3. Install thermometers on the inlet and outlet of the secondary side of each converter.

**O. Do not provide the following components, unless approved by the Director:**

1. Electric resistance heat
2. Variable Refrigerant Flow (VRF)
3. Furnaces

**P. Air Delivery Devices**

1. Ceiling diffusers or booted-plenum slots that are used in variable air volume systems must be specifically designed for VAV air distribution.

2. Booted plenum slots must not exceed 4 ft. in length unless more than one source of supply air is provided.
3. Select the locations of the air delivery devices and the ranges of their outlet airflow rates to ensure that the air diffusion performance index (ADPI) values remain above 80 percent during all full load and part-load conditions, and below the specified noise level to achieve the background noise criteria, in accordance with the test procedures specified in Appendix A of ASHRAE Standard 113.

**Q. Noise Control**

1. Subject to the restrictions noted elsewhere for duct lining, acoustic duct lining used in supply air systems shall be non-fiberglass material impregnated with an antimicrobial agent and covered by an internal perforated sheet metal liner.
2. Sound attenuators should only be used if other methods of noise reduction such as duct velocity reduction, lining, and fan location are inadequate to achieve noise performance requirements

## 4.0 LANDSCAPE AND IRRIGATION STANDARDS

Landscape irrigation sprinkler and emitter systems shall comply with the requirements of the ASABE/ICC 802-2014 Landscape Irrigation Sprinkler and Emitter Standard except as modified by this DFCM Design Requirements, Section 4.0

See **Appendix F for Site, Landscape, and Irrigation Design Requirements** and **Appendix G for Tree Protection and Preservation Policy**. Irrigation lines are considered a “utility” and should be located using the University of Utah Utility Locate Request form. Refer to here <https://facilities.utah.edu/utility-locate-request/>.

### 4.1 General

- A. Applicability. The provisions of this section shall apply to all projects on state property that involve the development or major modification of landscaping regardless of funding source, and all other projects under the jurisdiction of the DFCM or under state mandates. This section does not apply to:
  - 1. Registered Historical Sites
  - 2. Sites submitted for Design Variance due to unique context. Refer to section 1.4 Changes/Additions to Design Requirements for instructions on the design variance process.
- B. Site. The Design Requirements apply to all non-enclosed and non-building landscape areas within project limit lines or natural boundaries including restoration of construction damaged areas to the extent practical. Refer to section 3.2 Civil for site grading, parking requirements, sidewalks, and vehicular and service paths.
- C. Purpose. A purpose of this section is to designate site landscape standards for the design of attractive, water efficient landscapes that are sensitive to the geological and historical context of the site. The DFCM envisions landscapes that will endure because they are sensitive to the cultural, social, and aesthetic values of a community; the climate, water resources, and other environmental aspects of a location; and the financial investment of installation and maintenance over the life of the landscape. It is recognized that DFCM projects cover a wide range of community sizes, locations, and climates.
- D. Definitions
  - 1. For irrigation related definitions, refer to the following website by the Irrigation Association: <http://www.irrigation.org/>
  - 2. For planting related definitions, refer to the following website provided by Extension: [landscape-water-conservation.extension.org](http://landscape-water-conservation.extension.org)
- E. Designer(s). Architect or another licensed professional as recognized by the State of Utah to perform Landscape Architectural services and documents submitted to the DFCM including the Site Landscape Plan, Planting Plan and Irrigation Plan. Designers to meet state and local license, insurance and bonding requirements and be able to show proof of such upon demand.
- F. Contractor Qualifications and Experience. The Contractor(s), sub-contractors, installers, and others providing materials or services and installing the site landscape shall meet state and local license, insurance and bonding requirements and be able to show proof of such upon demand. Contractors to be directly involved in regular meetings with owner and DFCM and site inspection.
- G. Submittals
  - 1. Submit all described documentation in sections 4.3 and 4.4 to the Landscape Architect for review and approval prior to construction or substantial completion as indicated.
  - 2. Contractor to submit all product literature and customer service information for products used/installed on project to Landscape Architect for review and approval prior to installation.
- H. Construction Inspection and Post-Construction Monitoring

1. During construction, site inspection of the landscaping may be performed by the DFCM, the local institution or agency.
2. During construction a mainline pressure and leak test will be conducted.
3. Following construction an inspection shall be scheduled with the DFCM to verify compliance with the approved landscape and irrigation plans. A Certificate of Substantial Completion Form shall be completed by the Contractor or Landscape Architect and submitted to the DFCM.
4. Following construction a Water Use Efficiency Review (Audit) will be conducted by a certified Landscape Irrigation Auditor. The auditor shall be independent of the contractor, design firm and owner/developer of the project. The water performance audit will verify that the irrigation system complies with the minimum standards required by this ordinance. The auditor shall furnish a certificate to the DFCM, Landscape Architect, and installer certifying compliance with the minimum distribution requirements and an irrigation schedule.
5. The DFCM reserves the right to perform site inspections at any time before, during or after the irrigation system and landscape installation, and to require corrective measures if requirements of this guideline are not satisfied.

## 4.2 Water Allowance

- A. The finished installed site landscape shall be designed to be maintained within a designated Water Allowance. Landscape water consumption must be at or below the Water Allowance for the established landscape. In order for site plantings to become established during the first year after planting, watering amounts may exceed the established Water Allowance.
- B. Use the EPA WaterSense tool at the following website to create the water allowance for your site. [http://www.epa.gov/WaterSense/water\\_budget/](http://www.epa.gov/WaterSense/water_budget/). It is possible that the site and planting design will need to be adjusted to fit within the Water Allowance designated. Record the water allowance in the irrigation plans with the watering schedule; see section 4.7 B.
- C. For site landscapes with sports fields other justified planting or turf areas that may require more water than is designated by the Water Allowance, refer to section 1.4 Changes/Additions to Design Requirements for instructions on excusal from 4.2 A.
- D. The University of Utah is subject to State House Bill 121. Reference HB121 for context for water use including area of turf allowed, incentives for drought resistant landscaping, and requirements for annual metering/reporting.

## 4.3 Landscape Design Standards

- A. Create a Landscape Plan with the following Design Guidelines:
  1. Using the Water Allowance established for the sight, begin a water conscious design. Refer to the WaterSense website listed in section 4.2 to test percentages of turf and shrub areas to guide the design process.
  2. Topsoil Guidelines for Existing and Imported Topsoil
    - a. Imported topsoil installed on site to replace or augment existing soil on site shall be obtained from naturally drained areas and shall be fertile, friable loam suitable for plant growth. The imported topsoil shall be of uniform quality, free from subsoil stiff or lumpy clay, hard clods, hardpan, rocks, disintegrated debris, plants, roots, seeds, and any other materials that would be toxic or harmful to plant growth. Topsoil borrow shall contain no noxious weeds or noxious weed seeds.
    - b. Topsoil testing is required to ensure that all specifications below for either "Ideal" or "Acceptable" categories are met. Soils fall within the "Not- Acceptable" range shall not be used unless sufficient soil amendments are added to reach the approved categories.

Category	pH	Soluble Salts dS/m or	Sodium Absorption Ratio (SAR)	Organic Matter	Sand %	Silt %	Clay %	Texture Class
<b>Ideal</b>	5.5-7.5	<2	<3	≥2.0	<70	<70	<30	Loam (L), Silt Loam (SiL)
<b>Acceptable</b>	5.0-8.2	<4	3 to 7 SiL, SiCL, CL 3 to 10 SCL, SL, L	≥1.0	<70	<70	<30	Sandy Clay Loam (SCL) Sandy Loam (SL) Clay Loam (CL) Silty Clay Loam (SiCL)
<b>Not-Acceptable</b>	<5.0 >8.2	>4	>10	<1.0	≥70	≥70	≥30	Loamy Sand (LS) Sandy Clay (SC) Silty Clay (SiC) Sand (S), Silt (S), Clay (C)

**TOPSOIL QUALITY\***

**COARSE FRAGMENTS\***

Category	%>2 mm (>5.0% exceeds guidelines)	Rocks Present >1.5" (>1.5" exceeds guidelines)
<b>Ideal</b>	≤2.0	—
<b>Acceptable</b>	2.1-5.0	—
<b>Not-Acceptable</b>	>5.0	—

**TOPSOIL NUTRIENT SPECIFICATION\***

Category	Nitrate Nitrogen ppm	Phosphorus ppm	Potassium ppm	Iron ppm
<b>Ideal / Acceptable</b>	>20	>15	>150	>10

\*from "Topsoil Quality Guidelines for Landscaping", June 2002, AG/SO-02, prepared by Rich Koenig, Utah State University Cooperative Extension Soil Specialist, and Von Isaman, QA Consulting and Testing, LLC.

- c. Mechanical Analysis shall be performed and shall conform to ANSI/ ASTM D 422.
  - i. Soil Preparation and Amendments (fertilizers). Soil preparation shall be suitable to provide healthy growing conditions for the plants and to encourage water infiltration and penetration. Soil preparation shall include scarifying the soil to a minimum depth of six (6) inches and amending the soil with organic materials and fertilizers based on the Soils Report in order to reach the “Acceptable” or “Ideal” category of soil composition from the tables in 4.3 A. 2.Plant Selection. Choose site appropriate plant material. In most cases, this is water-efficient plant material. Refer to 4.1 C. to review the vision of DFCM landscapes.
  - ii. Park Strips. Park Strips and other landscaped areas less than 8 feet wide shall be landscaped with water conserving plants and/or grass. Areas less than 5 feet wide shall not be planted in turf.
  - iii. Practical Turf Areas. Plant turf only in areas of manageable sizes and shapes. Limit turf to areas where it provides a functional benefit. Selection of appropriate turf varieties should be determined by site location, functionality and climate. Excess turf may be replaced with a variety of other low water-use plants.
  - iv. Areas less than 5 feet wide shall not be planted in turf.
  - v. Areas with slopes greater than 33% shall not be planted with turf.
  - vi. Screening. Planting material should be used as a screening device for parking areas, service yards, transformers, and other site utilities etc. Trees in parking areas shall be selected based on reducing leaf litter and be “sap-drip” free.
  - vii. Mulching. Use bark or rock mulches in tree, shrub and perennial beds to conserve soil moisture and increase soil nutrients. Mulch applied at the right depth will reduce weed growth and slow erosion. Organic mulches such as bark improve soil over time.
  - viii. Appropriate Maintenance. Water-wise landscaping will reduce maintenance; however, it will not eliminate it. Low water-use landscapes are simply maintained differently than the average lawn. Maintain the landscape by pruning, fertilizing, watering, weeding mowing and proper deadheading of perennials and flowering plant material.

**B. Submit the following to the [DFCM University of Utah](#) for review and approval prior to construction:**

- 1. A Landscape Plan with the following indicated graphically and labeled:
  - a. Project name, location, designer contact information, project boundaries, project address, street names, existing and proposed buildings, walls, fences, utilities, paved areas and other site improvements
  - b. Locations of all proposed plant material, landscape materials, mulches, and all other site amenities
  - c. Plant Schedule indicating botanical name, common name, and size for trees, shrubs, perennials, groundcovers, and seed mixes
  - d. Proposed hardscape areas and materials within scope
  - e. Existing and proposed contours and spot elevations
  - f. Existing vegetation
  - g. Necessary details for landscape amenities and installation instructions
- 2. Specifications
- 3. Water Allowance Results Sheets(s) created from Step 3 of EPA WaterSense Tool

**C. Submit the following to the [DFCM University of Utah](#) for review and approval prior to substantial completion:**

- 1. As-Built Drawings
- 2. Operations and Maintenance Plan including the following:

- a. A signed and dated written description of the contractor's one-year landscape warranty period beginning from the date of substantial completion. Include name, address, phone number and license number.
- b. All product literature and customer service information for products used/installed on project.

#### 4.4 Irrigation Design Standards – See Appendix F – Site, Landscape, and Irrigation Design Requirements

##### A. Create an Irrigation Plan with the following Design Guidelines:

1. Recommended Point of Connection (POC) component installation order: 1-connection to source, 2-stop and waste valve/ or shut off, 3-filtration device, 4-pressure regulator, 5- backflow preventer, 6-quick coupler blowout, 7-master valve, and 8-flow meter – (if required).
2. In situations of secondary water supply, provide filtration system necessary to clean water supply and protect irrigation system components. Provide accessible pressure gauges immediately upstream and downstream of the filtration device. (Non self-cleaning units)
3. Landscape Water Meter. A separate irrigation system water meter and backflow prevention assembly that are in compliance with state code shall be installed for all new landscape irrigation systems. The landscape water meter and backflow prevention assembly shall be separate from the water meter and backflow prevention assembly installed for indoor uses. The size of the meter shall be determined based on irrigation demand.
  - a. See Section 4.2 Water Allowance for references to State House Bill 121
4. Pressure Regulation. A pressure regulating valve shall be installed and maintained by the consumer if the static service pressure exceeds 80 pounds per square inch (psi). The pressure-regulating valve shall be located between the landscape water meter and the first point of water use or first point of division in the pipe and shall be set at the manufacture's recommended pressure for sprinklers and or drip/micro systems. Pressure regulation devices may include one or all of the following: 1-pressure regulation valve at the main line POC, 2-pressure regulation device on individual sprinkler heads, 3- regulation of low volume drip/micro systems.
5. Irrigation systems with 1" POC or 10,000 square feet and larger of landscaped area shall have a flow sensor and master valve installed. Systems with irrigated area of 1 acre and larger shall have a normally closed master valve. Where necessary, the master valve shall be capable of manual operation to allow manual use of the irrigation system. A normally open master valve is acceptable if the controller is capable to shut the valve off in event of unscheduled flow.
6. Automatic Controller. All irrigation systems shall include an electric automatic controller with multiple programs and multiple repeat cycle capabilities and a flexible calendar program. Controller shall be programmable for multiple start times for repeat and rest periods, and shall be capable of water budget adjustment. Controller shall be able to provide separate programs for turf zones, shrub zones, and drip zones. All controllers shall be capable of temporarily shutting down the system by utilizing internal/external options (such as rain, wind, and freeze devices) and the ability to adjust run times based on a percentage of maximum ET or by use of a soil sensor. Power wire and control wire shall not be contained in the same conduit.
7. On slopes exceeding 33%, the irrigation system shall consist of Drip Emitters, Bubblers or sprinklers with a maximum Precipitation Rate of 0.85 inches per hour and adjusted sprinkler cycle to eliminate Runoff. Lateral lines are to run parallel to slope when possible.
8. Each valve shall irrigate a landscape with similar site, slope and soil conditions and plant materials with similar watering needs. Turf and non-turf areas shall be irrigated on separate valves. No single zone shall be designed or installed with sprinklers of differing pressure requirements or precipitation rates. (Rotors, spray heads, drip emitters, micro sprays, etc. may not be mixed within a zone.
9. Drip Emitters or Bubblers shall be provided for each tree where practicable. Bubblers shall not exceed 1.5 gallons per minute per device. Bubblers for trees shall be placed on a separate valve unless specifically exempted by the DFCM.

10. Sprinklers shall have matched Precipitation Rates with each control valve circuit. All sprinkler heads shall be spaced at a maximum of 50% of design performance diameter of the sprinkler. In known windy areas sprinklers are to be designed with reduced head spacing or low angle nozzles. Spacing shall be reduced below 50% of design performance diameter when conditions demand.
  11. Check valves shall be required where elevation differences will cause low-head drainage. Pressure compensating valves and sprinklers shall be required where a significant variation in water pressure will occur within the irrigation system due to elevation differences.
  12. Drip Irrigation lines shall be placed underground or otherwise permanently covered, except for Drip Emitters and where approved as a temporary installation. Filters and end flush valves shall be provided as necessary and as per industry standards.
  13. Irrigation zones with overhead spray or stream sprinklers shall be designed to operate between 8:00 P.M. and 8:00 A. M. to reduce water loss from wind and evaporation. Drip or bubbler zones are excluded from this requirement.
  14. Program valves for multiple repeat cycles where necessary to reduce runoff, particularly slopes and soils with slow infiltration rates.
- B. Submit the following to the [DFCM University of Utah](#) for review and approval prior to construction:
1. An Irrigation Plan with the following indicated graphically and labeled:
    - b. Project name, location, designer contact information, project boundaries, project address, street names, existing and proposed buildings, walls, fences, utilities, paved areas and other site improvements
    - c. Points of Connection present and future with static water pressure
    - d. Water meters
    - e. Pumps and sumps
    - f. Controller location(s), note manufacturer, model, size and number of stations used and central control
    - g. Lines and sizes, i.e. lateral, main, and pressure mains
    - h. Sleeve locations and sizes
    - i. Backflow preventers, quick couplers and hose bibs
    - j. Drip system pressure regulators and filters
    - k. Wire, i.e. control, remote control, and control wire junction boxes; label both ends and in junction box
    - l. Control valves, i.e. master, remote control, flush, pressure reducing, drip, etc., note station assignment, size, flow rate, pressure setting. D.U. and actual flow rates, if available from water audit for applicable valves
    - m. Sensors, i.e. rain, flow, and moisture
    - n. All sprinkler heads, rotary nozzles, bubblers, etc.
    - o. Capped lines and irrigation system removed or abandoned
    - p. Identify locations of existing utility systems encountered during installation, i.e.; gas, phone, sewer, etc.
    - q. Valve Schedule with flow rates in GPM for each valve
    - r. Watering Schedule listing valve station no. plant type, irrigation type, precipitation rate, and water times for initial plant establishment and post plant establishment
    - s. Irrigation Component Schedule
    - t. Necessary details and installation instructions
  2. Specifications

## 5.0 STATE OF UTAH HIGH-PERFORMANCE BUILDING STANDARD (HPBS)

### 5.01 Intent

- A. The intent of the High Performance Building Standard is to improve building performance, and reduce the total cost of ownership for the State of Utah. The State of Utah and State Agencies own and operate buildings for the total life of the building, which is 40 years, minimum, and optimally 100 years and beyond.
  - a. In addition High Performance Building Standards, University projects are encouraged to pursue a minimum of LEED Silver Certification where construction costs exceed \$10MM and it aligns with project goals. The University has experience meeting these requirements, which are reinforced by High Performance Building Standard requirements. Appendix H includes a reference guide the University's required LEED credits, where they complement the DFCM High Performance Building Standards.
- B. The cost of acquisition or construction of a new building is typically only 2% of the overall cost of ownership, over the life of a building. Beyond this initial cost of ownership, approximately 6% of the lifetime cost of ownership goes to fuel costs, operations, maintenance, repair costs, finance charges, and non-monetary costs. The remaining 92% of the cost of ownership is personnel costs<sup>1</sup>. Making good decisions with the money spent for construction results in a high performing building that allows the people working in it to be their most productive. Loss of productivity of employees due to uncomfortable or non performing work space has the biggest negative cost impact to an employer.
- C. The key elements of building and site design that impact the ongoing cost of ownership include:
  - 1. Building energy utilization (utility bills)
  - 2. System performance and durability (operations and maintenance)
  - 3. Occupant health and comfort which impacts employee productivity
- D. Recognizing that there are limitations on each project in the form of a fixed project construction budget and schedule, the State of Utah requires each project owner and design team to design and construct new facilities in accordance with the High Performance Building Standard.

### 5.02 Compliance:

The High Performance Building Standard applies to all DFCM capital development projects. However, to ensure the High-performance Building Standard is not placing undue burden on smaller projects, there are variations from the standard that are appropriate for projects that fall below a specific size and/or budget, and projects that are located in remote areas of the State. Some of the known variations for specific requirements of this standard are outlined throughout the standard. In all cases variations need to be discussed with the DFCM High Performance Program Director. Once a consensus is reached between the Program Director and the project team a variance form needs to be submitted to the Program Manager for signature and filed with the other HPBS project documentation requirements.

In order to promote full adoption of this standard, and encourage a timely submission of documentations, 2% of both the design fees and general contractor fees will be withheld until all the required documentation is submitted. Once all of the documentation is submitted and reviewed by DFCM, DFCM will determine if the project has successfully met the High Performance Building Standards, including acknowledgement of any approved variances. The clarity and quality of the documentation along with a clear intent to meet the requirements of this standard will be one of the requirements for the design firm and contracting firm to receive a rating of 5 on Quality of Product or Service on their DFCM performance rating. Other issues on the project could preclude the design firm or contractor from receiving a 5 in this category even if the project is determined to be a High Performance Building in accordance with the State's High Performance Building Standard.

### 5.03 Deliverables:

---

<sup>1</sup> <https://www.wbdg.org/resources/life-cycle-cost-analysis-lcca>

Project teams shall demonstrate compliance with the High-performance Building Standard by submitting the HPBS Project Checklist (Appendix A) and associated required submission information at each project phase milestone.

## 5.1 Integrated Design Process

**5.1.1 Summary / Intent:** Integrated design is the process of engaging a more comprehensive team early in the programming and design processes.

- A. “An integrated process is highly collaborative. This approach requires the whole project team to think of the entire building and all of its systems together, emphasizing connections and improving communication among professionals and stakeholders throughout the life of a project. It breaks down disciplinary boundaries and rejects linear planning and design processes that can lead to inefficient solutions. Although the term integrated design is most often applied to new construction or renovations, an integrated process is applicable to any phase in the life cycle of a building.”<sup>2</sup>
- B. Key team members that are required within an integrated design include:
1. DFCM Project Manager
  2. DFCM HPBS Program Manager
  3. Agency Project Manager
  4. Facilities Manager (management team, as defined by DFCM and the Agency)
  5. User Representatives
  6. Architect
  7. Landscape Architect
  8. Civil Engineer
  9. Structural Engineer
  10. Mechanical/Plumbing Engineer
  11. Electrical Engineer
  12. Energy Modeler (as applicable)
  13. Commissioning Authorities (building systems and envelope, as applicable)
- C. Engaging a holistic project team early in the planning and design process enables the most effective outcomes for the project. The skills of each team member can be leveraged early, at a time when informed decisions have their greatest positive impact. This holistic engagement also promotes quality project documents responding to specific project needs, and State Standards.
- D. The DFCM, Agency, and members of the integrated design team outlined in the previous section all have unique responsibilities in their support of the integrated design process. The DFCM HPBS program manager shall promote the entire process through the early organization of all required parties and tracking progress on required documentation. The Agency will be required to articulate project objectives and criteria. The architect and consulting engineers will record and synthesize this information and maintain the OPR and BOD documents during the design phase, as discussed below. Once the design is completed, these documents will be transferred to the commissioning team for verification.
- E. Two documents are used to record and track results of the integrated design process.
1. The Owner’s Project Requirements (OPR) is an outline of the goals and requirements DFCM and the agency feel are important to the success of the project. The OPR is a product of the programming phase of development and should be updated as project requirements are redefined throughout the project. In fact, the OPR shall record project development decisions and provide insight into the drivers of those decisions. The OPR also serves as a primary reference for the commissioning agents throughout the project. An OPR template is available as Appendix B.

---

<sup>2</sup> <https://www.usgbc.org/articles/green-building-101-what-integrated-process>

2. The Basis of Design (BOD) document is a product of the design team and is used to articulate how the OPR is to be achieved in the design. This is also a living document requiring regular updates. The commissioning agents will assess the BOD at each design milestone for compliance with the OPR.

### **5.1.2 Compliance / Programming Phase**

- A. Conduct a project kick-off meeting, where the DFCM and Agency present the Project Overview, introduce building performance standards and expectations, and determine the Steering Committee or decision makers for the project. Any sustainability goals exceeding those required by the High Performance Building Standard shall be identified. The information being presented at this point from the Owner/Agency group is the initial content for the Owner's Project Requirements. Using an OPR template to create this presentation is highly recommended.
- B. As determined at the project kick-off meeting, moderate and high complexity projects will require a dedicated High Performance Workshop to vet specific sustainable design strategies and to align the overall project approach with the High Performance Building Standard.
- C. An OPR draft shall be included as part of the final programming documents submitted to DFCM.

### **5.1.3 Design and Construction Phases**

- A. The team shall hold a High-Performance Building Workshop as early in the formal design process as possible. This workshop shall include all of the team members required for the integrated design process. The agenda and discussions for the workshop shall address the key requirements of the High-Performance Building Standard and directly engage with the requirements identified in the OPR. Although open-ended exploration may be appropriate in the workshop, the intent of the meeting is to begin evaluating project-specific strategies. It is the design team's responsibility to bring early-stage analysis results to this meeting in order to inform decisions about what direction the project will take.
- B. An HPBS update meeting shall be held at the mid-point of each design phase with the attendees from the initial workshop to confirm the project is on track to meet the goals and vision set forth for the project, and meet the requirements of the High Performance Building Standard.
- C. Throughout all design phases, the OPR shall be maintained to accurately record changes in the project requirements.

### **5.1.4 Deliverables**

- A. Programming: OPR draft, completed project checklist for programming (Appendix A) and final programming documents submitted to DFCM.
- B. Design and Construction: First draft of the BOD after first HPBS workshop in SDs, updated OPR and BOD, and updated project checklist submitted with each subsequent design submission.

## 5.2 Community-Oriented Design

### 5.2.1 Summary / Intent

- A. The project team shall conduct a review of campus, local, and regional planning documents to better understand the vision set forth for the site. This assessment should also include a review of appropriate transportation planning documents to enable the team to plan for the transportation and transit vision for the site, beyond the existing conditions.
  - 1. Key planning documents may include, but are not limited to:
    - a. Campus or regional master plan or land use plan
    - b. Open space, trail and/or recreation plans
    - c. Municipal, regional or state transportation plans
    - d. Local or Regional stormwater plans and/or guidelines
    - e. Applicable environmental regulations that may apply to the site
- B. In addition to reviewing pertinent planning documents, the team should consider access between the project site and community. Each project undertaken by the State of Utah should contribute to enhance connectivity between the site and key community amenities. It will also improve access to the site for the greater community, this is especially important if the functions within the building include public facing services.

### 5.2.2 Compliance

- A. Provide a summary of key findings from reviewed planning documents that impact the Owner's expectations of performance within the OPR as well as a narrative demonstrating how these expectations are being addressed in the design within the BOD. This narrative should include any impacts to the overall site or building design.
- B. Ensure pedestrian paths are safe, accessible and maintainable by facility staff. This includes, but is not limited to, providing walkways that are minimum of 5'-0" wide, and ADA compliant. On steep sites, provide one or more ADA accessible primary pedestrian pathways.
- C. Provide safe pedestrian pathways, separate from parking areas between the public right-of-way and the primary public entry. Identify these pathways on the project site plan. Plan for both bicycle / scooter access as well as pedestrian access.
- D. Programming / Schematic Design - Owner's Project Requirements – Include a narrative of the owner's expectation for Community-Oriented Design in the OPR.

- 5.2.3 **Deliverables:** HPBS Project Checklist (Appendix A) and associated required submission information at each project phase milestone.

## 5.3 Transportation Management

**5.3.1 Summary / Intent:** The project site and building design shall reduce the impacts of single occupant vehicles by promoting alternative transportation and people powered, low-emitting and fuel-efficient vehicles.

### 5.3.2 Compliance

- A. Projects shall not exceed the DFCM recommended parking, based on project use, size and location, identified in section 5.3.4.
- B. Provide bicycle racks for a minimum of 10 bicycles at the primary public entry, or demonstrate compliance with an established bicycle master plan. After the course of one-year, facility management shall assess the need to for additional bicycle racks and provide additional racks as necessary. Locations for bike racks shall be identified during design and indicated on the design documents.
- C. Projects shall implement three or more of the following strategies to reduce single occupant vehicles ridership to and from the project site:
  - 1. Provide free or reduced fee UTA or applicable transit passes for all building staff.
  - 2. Where a parking fee is in place, provide a reduced fee for carpool or electric vehicles.
  - 3. Complete a parking assessment to ensure alignment of parking needs with actual anticipated staff on-site each day.
  - 4. Motivate transit use by implementing a parking fee.
  - 5. Provide tele-working and / or reduced workweek programs for a minimum of 30% of building staff.
  - 6. Provide shower and changing rooms as well as indoor, secure bicycle storage. These shall be located near the pedestrian pathways from the building to the public right-of-way.
  - 7. Provide electric vehicle charging stations for 4-6% of parking provided on-site, locate these in preferred locations, near public and staff entryways.
  - 8. Demonstrate single-vehicle ridership or vehicle impact reductions through an alternative method.

**5.3.3 Deliverables:** HPBS Project Checklist (Appendix A) and associated required submission information at each project phase milestone.

**5.3.4 Additional Resources:** Parking quantities for new construction projects:

- A. Office: 0.8 parking stalls per employee
- B. Courthouse: 2.5 stalls per 1,000 gross square feet of building area
- C. Liquor Store: 4 stalls per 1,000 gross square feet of building area
- D. Higher Education: Minimum determined by the campus administration, or 0.3 stalls per campus population, if no standard exists
- E. Research Facility: 0.8 stalls per employee plus visitor stalls as determined by the user.
- F. Data Center: 0.8 parking stalls per employee
- G. Healthcare Facilities: 4 stalls per 1,000 gross square feet of building area

## 5.4 Site Design

**5.4.1 Summary / Intent:** Enhance access within the site, improve flow and overall project functionality, and reduce the environmental impacts of the project site design.

### 5.4.2 Compliance

- A. **Building Location and Orientation:** The building should be oriented and located to respond to the local context, be inviting and welcoming and improve the overall community fabric. In addition, the following considerations will affect the siting and orienting the building footprint:
1. Locate the building with the long axis east/west to the extent feasible. This will ensure the majority of the façade faces north/south allowing for effective, controllable daylight within the building.
  2. Locate and orient the building to provide a clear public entry visible from the public right-of-way.
  3. Locate the building to respect the setbacks within the community and zone district, as applicable to the project type.
  4. Locate the building outside of any known flood zones.
  5. Locate the building to preserve any meaningful native flora and fauna that may exist on the project site.
- B. **Access and Site Circulation:** Ensure all vehicular, pedestrian, and bicycle access to the project site, as well as within and around the site, is intuitive and safe.
1. Provide clear pedestrian paths from the public right-of-way to the building entry.
  2. Provide clear vehicular access from the public right-of-way to the vehicular access and parking within the project site.
  3. Ensure any pedestrian access that crosses a vehicular or service path is clearly marked and the pedestrian path prioritized over the vehicular path.
- C. **Open Space Design:** Project should provide meaningful outdoor space. When designing outdoor space, define key areas for meaningful outdoor use. These may include, but are not limited to:
1. Outdoor recreation area with grass for active recreation use.
  2. Outdoor respite area for staff and/or visitors with comfortable seating, shade and a mixture of hardscape and landscaped spaces. This may include a staff break patio, an outdoor seating area for visitors or shared outdoor space.
  3. Outdoor activity space such as a walking path for community wellness.
  4. Outdoor spaces should be designed to enhance social interactions to improve personal health and wellness, as well as professional satisfaction.
  5. All usable outdoor spaces should be designed with personal health/wellness in mind. This includes the integration of deciduous trees or other structures for shade in the warmer summer months, providing appropriate furniture based on the intended use of the space and integration of effective landscape.
  6. Design the project landscape and irrigation systems per Chapter 4 of the DFCM Design and Construction Standards.

**D. Stormwater Management**

1. Design, construct, and maintain Stormwater Best Management Practices (BMPs) that manage rainfall on site and prevent the off-site discharge of precipitation from the first one inch of rainfall from a 24 hour storm preceded by 48-hours of no measurable precipitation.
2. Implement at least two BMPs from the Best Management Practices for Stormwater<sup>3</sup> OR maintain all stormwater on site. This option is for campuses that already have this requirement.

**E. Urban Heat-Island Effect: Plan exterior hardscape materials, and shade parking to reduce the urban heat-island effect on the site. Implement a minimum of one of the following:**

1. Plant deciduous trees to shade 15% of the surface of any asphalt parking lot within 10 years of planting.
2. Use concrete or light-colored pavers with a SRI Value of 29 equal to or greater in lieu of asphalt for 25% of the parking surface.
3. Use shade structures or solar panels to shade a minimum of 15% of the surface of any asphalt parking lot.
4. Provide structured parking, covering a minimum of 50% of the parking surface.
5. Projects shall also use concrete or light-colored pavers or pavement at all pedestrian oriented hardscape areas. Colored concrete shall not have a 90-day aged SRI equal to or greater than 29.
6. Use reflective roofing to reduce the urban heat-island effect at the building.
  - a. Install a reflective roof with an SRI of 78 or greater over 75% of the low slope roof areas (slopes below or equal to 2:12) for all buildings in Climate Zones 3 and 5.
  - b. Install roofing with an SRI of 29 or greater at steep-sloped areas (slopes above 2:12)
  - c. Consider a tan colored, planted or ballasted roof at roofs that are visible from inside the building to reduce glare and increase occupant comfort.
  - d. Darker roofs shall be considered in Climate Zone 6, where heat absorption may be beneficial to the overall energy use of the building.

**F. Light Pollution Reduction**

1. All exterior lighting shall be dark sky approved through the International Dark Sky Association<sup>4</sup>.
2. Use fixtures that are as low in height as feasible, to ensure light is at the appropriate location for pedestrian safety and functionality.
3. All exterior lamps shall be LED.
4. Exterior lighting shall be controlled by a photocell sensor.
5. All interior lighting systems on non-residential facilities shall be designed and controlled to shield interior light from the exterior of the building, or include a 50% reduction in lighting output between the hours of 11:00 PM and 5:00 AM. Interior lighting shall be controlled to turn off or reduce when a space is not in use.
6. Emergency lighting shall only be provided when the space is occupied or in the event of a power failure.
7. **See Appendix D Outdoor Lighting System Standards for UofU requirements.**

**5.4.3 Deliverables:** HPBS Project Checklist (Appendix A) and associated required submission information at each project phase milestone.

---

<sup>3</sup> <https://www.epa.gov/greeningepa/stormwater-management-practices-epa-facilities>

<sup>4</sup> <https://www.darksky.org/>

## 5.5 Building Performance

**5.5.1 Summary / Intent:** Facility energy use comprises a significant portion of the operating cost of a building. Defining energy performance requirements early on in the design process allows the State of Utah to control building operational costs and establishes a site-specific benchmark in comparing the ongoing operation and maintenance of the facility. If an Institute of Higher Education has sustainability goals beyond this section, such as Carbon Neutrality, DFCM will support those goals while adhering to these standards as closely as possible.

### 5.5.2 Energy Modeling

- A. Summary / Intent:** All state agencies and institutions shall design, construct, and operate new construction and major renovation, commercial and multi-family high-rise buildings to achieve a measured source EUI less than or equal to a DFCM provided ‘outcome based’ performance target. The term ‘outcome based’ refers to a policy that is based on the actual measured performance of a building after all energy consuming systems are installed, commissioned, and the building has been occupied for a minimum continuous 12 month period. The building shall demonstrate a measured source EUI less than or equal to the DFCM provided performance target provided in Appendix D Building Performance Worksheet, for the building type, climate zone, and construction permit date.
- B. Compliance:** The energy engineer shall develop a whole building energy model consistent with the requirements of this section using qualified federal tax deduction software<sup>5</sup> or alternate methodologies that are approved by the DFCM Building Performance Program Manager.
- The source energy use intensity (EUI) based performance target is established based upon facility type, year of permit, and ASHRAE climate zone (3B, 5B, or 6B). Source Energy Performance Targets are provided in Appendix D. The energy targets provided deliver high performance, low cost of operation, while providing project teams more flexibility in selecting cost effective whole building design strategies.
  - For the purpose of calculating the projected source energy, include all fuel sources consumed for all systems normally specified as part of the proposed design scope, including receptacle and process load energy. The source energy EUI shall be calculated as follows:

$$\text{Source EUI } \left( \frac{\text{kbtu}}{\text{ft}^2} / \text{yr} \right) = \frac{\text{Annual building source energy use (kbtu)}}{\text{Gross floor area (square foot)}}$$

Where:

**Source energy use** includes all primary fuel sources plus all delivery and production losses.

**Gross floor area** includes all areas contained within the exterior walls and roof of the building. Gross floor area does not include exterior spaces such as balconies, loading docks, driveways, play course, parking areas, plenum space between floors, crawl spaces, etc.

The following source conversion factors, sourced from EPA Portfolio Manager<sup>5</sup>, shall be applied in calculating the total annual source energy.

Energy Type	Source Energy Conversion Factor
Imported Electricity	2.80 (assumes no off-site renewable energy)
Natural Gas	1.05

<sup>5</sup> <https://www.energy.gov/eere/buildings/qualified-software-calculating-commercial-building-tax-deductions>

Steam	1.20
Hot Water	1.20
Chilled Water	0.91

3. If the building has multiple occupancy types with significantly different operating conditions or thermal loads, the maximum allowable energy use shall be based on a ratio of gross floor area of each occupancy type in relation to the total gross floor area of all occupancy types within the building. Examples of where this exception may be applicable includes but is not limited to natatoriums, continually occupied security areas, large server rooms, and large refrigerated storage space.
4. Regulated loads (envelope, lighting, HVAC) shall be the focus of the modeling effort as unregulated loads must be simulated per mandatory schedules provided, unless specific alternative schedules are pre-approved by the DFCM Building Performance Program Director.
5. Unregulated (plug/process/miscellaneous equipment) loads and schedules shall align with latest COMNET<sup>6</sup> intensity values and schedules.
6. The building enclosure must limit the amount of vertical fenestration area to no more than 30% of the above-grade wall area. Spandrel shall be insulated to opaque wall minimum insulation requirements. If Spandrel is not insulated to the opaque minimum insulation requirements it will contribute to the 30% limit.
7. The predictive energy model shall account for building envelope thermal bridging. Simulated envelope properties shall be de-rated to account for thermal bridging per Section 5.5.4.2.5 of this standard.
8. Projected annual emissions data shall be reported as part of the design submittal. eGrid 2018 State Output Emissions Rates or the current version of this reference shall be applied for electric consumption emission factors and U.S. EIA AP-42 shall be applied for natural gas emission factors. Carbon Dioxide (CO<sub>2</sub>), Sulfur Dioxide (SO<sub>2</sub>), and Nitrogen Oxide (NO<sub>x</sub>) shall be reported at a minimum. Results should be documented in Appendix D Energy Performance Documentation.
9. Normalizing for abnormal occupancy conditions: Operating shift multipliers may be applied to the performance target where the expected runtime varies from traditional weekly operating hours. For example, an office building that operates continuously. When applying for this pre-approved exception, ASHRAE Standard 100 operating shift multipliers (table J-5) should be considered as the basis for the adjustment.
10. Buildings or projects with a conditioned floor area less than 30,000 FT<sup>2</sup>, or less than \$5,000,000 total project budget, or a projected site EUI of less than 20 kbtu/FT<sup>2</sup> /yr may, by discretion of the DFCM Building Performance Program Manager, be exempt from section 5.5.2.
11. Projects exempted from section 5.5.2 by the DFCM Building Performance Program Manager are required to incorporate qualitative design assist from a state hired Energy Engineer.
12. Alternative path of compliance for non-traditional building types: Buildings having one or more uses or occupancies not listed in Appendix D shall not be eligible to demonstrate compliance with this code in accordance with this section. The following alternative path of compliance shall be used:
  - a. All state agencies and institutions shall design new construction and major renovation, commercial and multi-family high-rise building types not listed in Appendix D to achieve, if life-cycle cost-effective, a Performance Cost Index that is at least 15% lower than the Performance Cost Index Target (PCI<sub>t</sub>) when calculated per the methodology outlined in *ANSI/ASHRAE/IESNA Standard 90.1-2016* Section 4.2.1.1 and Appendix G.
    - i. For the purpose of calculating the Performance Cost Index, include all fuel costs incurred for all systems normally specified as part of the Proposed design scope, regardless of specifying entity (interior and exterior), including receptacle and process load energy costs.

- ii. Energy costs for both the Baseline and Proposed designs shall be determined by using the Performance Rating Method as defined by Appendix G of *ANSI/ASHRAE/IESNA Standard 90.1-2016, Energy Standard for Buildings Except Low-Rise Residential Buildings*<sup>6</sup>.

### C. Deliverables

1. Programming/ Schematic Design: Include a narrative of the owner's expectations for Energy Performance in the OPR.
2. Design Phases: Energy Model and Appendix D, or appropriate verification of energy compliance, at each project phase milestone. Updated OPR and BOD for building performance to be completed by design and energy consulting team.
3. Construction and Occupancy: The commissioning agent and the building owner shall define a strategy in which the performance targets will be validated. At a minimum, this strategy will define expected date of CO receipt, expected data in which project will be considered fully commissioned, a 6-month check-in period, a 9-month check-in period, and date in which final compliance shall be documented. Utility data shall be documented in Appendix D for all check-in periods.
4. Final Deliverable: Within 24 months of issuance of the certificate of occupancy, the building commissioning team shall provide the DFCM with documentation of a continuous 12-month period where the building complies with this section, and provide a written narrative comparing the proposed building source EUI submitted at design to actual energy use. This narrative should reflect a good-faith effort to understand variations between predicted and actual energy use for the project. DFCM expects the project team to collaboratively identify causation and potential solutions if a building does not meet the planned for EUI target or 15% utility cost savings target.
5. All EUI information should be weather-normalized to ensure variation due to abnormal weather does not skew the data.

---

<sup>6</sup> [ANSI/ASHRAE/IESNA Standard 90.1-2016, Energy Standard for Buildings Except Low-Rise Residential Buildings](#)

### 5.5.3 Water Use Reduction

#### A. Summary / Intent

1. Reduce ongoing water utilization through thoughtful and efficient system design.

#### B. Compliance

1. Landscape Water Use
  - a. The project landscape and irrigation systems per Chapter 4 of the DFCM Design and Construction Standards.
  - b. Turf grass and sprinklers shall only be used at active landscape areas that are a minimum of fifteen feet in any direction and a minimum of 200 square feet. Exceptions to this shall be justified by local landscape and/or zoning standards. Any alternate use must be reviewed and approved by the DFCM Building Performance Program Director.
  - c. Generate a Landscape Water Budget using the WaterSense Water Budget Tool<sup>7</sup>. Demonstrate a 50% reduction in landscape water use.
  - d. The Landscape Architect shall provide an estimated maintenance schedule for the landscaped areas, with an emphasis on the reduced maintenance and reduced water consumption of the native and adapted landscaped areas. This maintenance schedule shall be required in the project specifications and included in the Operation and Maintenance Manuals for the project.
2. Plumbing Fixture Water Use: Specify WaterSense qualified fixtures<sup>8</sup>, as applicable, for all interior plumbing fixtures.
3. Process Water Use: Once-through process water systems are not permitted in buildings other than labs and hospitals. Labs, hospitals and other facilities with complex sterilization or equipment shall provide a narrative of systems requiring once-through process water.

- C. **Deliverables:** HPBS Project Checklist (Appendix A) and associated required submission information at each project phase milestone.

### 5.5.4 Building Enclosure Performance / Commissioning

#### A. Summary / Intent

1. High performance building enclosures shall be commissioned in general compliance with the most recent version of ASTM E2813, Standard Practice for Building Enclosure Commissioning. Where conflicts arise between ASTM E2813 and this Standard, this Standard shall supersede.
2. Per ASTM E2813, Building Enclosure Commissioning (BECx) is a process that begins with the establishment of the Owner's Project Requirements (OPR) and endeavors to confirm that the exterior enclosure and those elements intended to provide environmental separation within a building or structure meet or exceed the expectations of the Owner as described in the OPR, and as defined by the contract documents.
3. Refer to Appendix E for additional information related to BECx and building enclosure requirements.

---

<sup>7</sup> <https://www.epa.gov/watersense/water-budget-tool>

<sup>8</sup> <https://www.epa.gov/watersense/watersense-products>

**B. Compliance**

1. DFCM will engage a qualified Building Enclosure Commissioning Agent (BECxA) prior to or during the schematic design phase for all Enhanced BECx scope projects, but no later than the design development phase for all projects that utilize BECx.
2. Levels of BECx: There are two levels (Fundamental and Enhanced) of performance for High Performance Buildings, generally related to the project budget/size and complexity. Note that “Fundamental” and “Enhanced” is not intended to align with the scope identified in ASTM E2813. Enhanced BECx shall follow the most stringent performance requirements and complete scope as outlined in the HPBS. For Fundamental BECx, the following deviations from the BECx process outlined in this standard may apply:
  - a. The BECx budget will dictate the scope required. In general, modifications to the BECx scope when Fundamental BECx is acceptable may consist of the following:
    - i. BECxA engagement during the Design Development phase.
    - ii. cursory or less in depth reviews of drawings/ specifications.
    - iii. In-situ mock-up in lieu of stand-alone mock-up.
    - iv. Fewer building enclosure site reviews and functional performance testing during construction.
    - v. Post-occupancy site review not performed.
  - b. Training meeting with facilities staff not performed. A less stringent whole building air leakage requirement may be identified and used for whole building air leakage testing, or whole building air leakage testing will not be performed.

The following table can be used as a guide to identify Fundamental BECx and Enhanced BECx projects:

	<b>Architectural Project Complexity</b>				
<b>Budget is Above</b>	<b>Schedule A</b>	<b>Schedule B</b>	<b>Schedule C</b>	<b>Schedule D</b>	<b>Schedule E</b>
<b>\$0</b>	Fundamental	Fundamental	Fundamental	Fundamental	Fundamental
<b>\$50,000</b>	Fundamental	Fundamental	Fundamental	Fundamental	Fundamental
<b>\$100,000</b>	Fundamental	Fundamental	Fundamental	Fundamental	Fundamental
<b>\$150,000</b>	Fundamental	Fundamental	Fundamental	Fundamental	Fundamental
<b>\$200,000</b>	Fundamental	Fundamental	Fundamental	Fundamental	Fundamental
<b>\$300,000</b>	Fundamental	Fundamental	Fundamental	Fundamental	Fundamental
<b>\$500,000</b>	Fundamental	Fundamental	Fundamental	Fundamental	Fundamental
<b>\$750,000</b>	Fundamental	Fundamental	Fundamental	Fundamental	Fundamental
<b>\$1,000,000</b>	Fundamental	Fundamental	Fundamental	Fundamental	Enhanced
<b>\$1,500,000</b>	Fundamental	Fundamental	Fundamental	Fundamental	Enhanced
<b>\$2,000,000</b>	Fundamental	Fundamental	Fundamental	Fundamental	Enhanced
<b>\$3,000,000</b>	Fundamental	Fundamental	Fundamental	Fundamental	Enhanced

\$4,000,000	Fundamental	Fundamental	Fundamental	Fundamental	Enhanced
\$5,000,000	Fundamental	Enhanced	Enhanced	Enhanced	Enhanced
\$8,000,000	Fundamental	Enhanced	Enhanced	Enhanced	Enhanced
\$12,000,000	Fundamental	Enhanced	Enhanced	Enhanced	Enhanced
\$15,000,000	Fundamental	Enhanced	Enhanced	Enhanced	Enhanced
\$20,000,000	Fundamental	Enhanced	Enhanced	Enhanced	Enhanced
\$25,000,000	Fundamental	Enhanced	Enhanced	Enhanced	Enhanced
\$30,000,000	Fundamental	Enhanced	Enhanced	Enhanced	Enhanced
\$35,000,000	Fundamental	Enhanced	Enhanced	Enhanced	Enhanced
\$40,000,000	Fundamental	Enhanced	Enhanced	Enhanced	Enhanced
\$50,000,000	Fundamental	Enhanced	Enhanced	Enhanced	Enhanced

Note: Whole building air leakage testing may not need to be performed on the following buildings: complex parking structures, buildings with operable fenestration such as student housing, mixed-use housing, and stadiums that do not have enclosed conditioned spaces

3. Systems to be commissioned: The exterior enclosure systems to be commissioned responsible for environmental separation between conditioned interior spaces and the exterior environment with respect to air, water, thermal, and vapor, are as follows:
  - a. Below-grade or at grade enclosure elements such as foundation walls, elevator pits, slab-on-ground conditions, etc.
  - b. Above-grade exterior enclosure systems such as opaque walls, fenestration, low-slope roofing, steep-slope roofing, horizontal and deck conditions, expansion/movement/ deflection joints, skylights, etc.
  - c. The interfaces between all exterior enclosure components including sealants, flashings, joints, etc.
  - d. Interior enclosures that separate two or more distinct environments as required by the project.
4. Building enclosure commissioning scope of work by project phase:
  - a. Schematic Design Phase
    - i. *Owner's Project Requirements:* The Owner and Architect/Engineer of Record (A/E) will identify and document the Owner's Project Requirements (OPR), relative to the building enclosure systems selected for commissioning in order to establish a baseline of performance expectations to which the installed performance is compared. Refer to ASTM E2813 for typical project and performance requirements included in the OPR. The BECxA can assist with the development of the OPR as needed.
    - ii. *Design Coordination Meeting:* A BECx Coordination Meeting shall be initiated by the BECxA with attendance of the A/E, energy modeler, mechanical engineer, and DFCM representative. Topics to be covered during the coordination meeting include, but are not limited to, the BECx process, communication protocols, development of OPR and BOD, and coordination of the building enclosure performance characteristics related to energy performance. The design coordination activities may be included as part of the OPR Coordination Meeting.
    - iii. *Basis of Design:* The Basis of Design (BOD) is to be developed by the A/E. The intent of the BOD identifies the concepts, calculations, decisions, and materials to be used in the design to meet the OPR and to satisfy applicable regulatory requirements, codes, standards, and guidelines. The document generally includes both narrative descriptions and lists of

individual items that support the design process. The BECxA reviews the BOD and design narrative documentation and provides written review comments to the project team.

- iv. *BECx Plan*: The BECxA will develop the BECx plan. The plan shall include key elements including, but not limited to, project schedule inclusive of BECx tasks and milestones, systems to be commissioned, roles and responsibilities of commissioning team members, means of communication, reporting of conditions and progress throughout the BECx process, and the level of documentation expected throughout the BECx process. The plan is updated periodically throughout the BECx process to reflect changing project conditions or requirements until the end of the project, when it then becomes the project BECx Record.
- v. *Design Review*: The BECxA shall review the schematic design documents to assist with the development of a building enclosure that provides effective environmental separation to meet the OPR. The design concepts will be evaluated against the OPR and BOD. Deliverables typically consist of written mark-ups of the architectural drawings and project specifications to be shared and discussed with the project team. The BECxA shall track comments and resolution. The A/E provides a written response to the BECxA and Owner as to how the comments will be reflected in the final design documents.

b. Design Development and Construction Documents Phase

- i. *Design Review*: The BECxA shall review the relevant project documents to assist with the development of a building enclosure that provides effective environmental separation to meet the OPR. The design concepts will be evaluated against the OPR and BOD. A minimum of four reviews of the drawings and three reviews of the project specifications are required by the BECxA, with the final reviews consisting of a back-check of previous review comments. Deliverables typically consist of written mark-ups of the architectural drawings and project specifications to be shared and discussed with the project team. The BECxA shall track comments and resolution. The A/E provides a written response to the BECxA and Owner as to how the comments will be reflected in the final design documents. In general, the reviews shall occur of the following design deliverables:
  - 100% Design Development – Drawing Review
  - 100% Design Development - Outline Specifications Review
  - 50% Construction Documents – Drawing Review
  - 50% Construction Documents – Specifications Review
  - 90% Construction Documents – Drawing Review
  - Bid Set – Back Check of Drawings
  - Bid Set – Back Check of Specifications
- ii. Back checks performed of the bid set shall be conducted such that outstanding comments not addressed can be addressed by the A/E can be addressed for the final set of Conformance Set.
  - Design Review Meetings: BECxA will meet in person with the A/E and other applicable team members. There shall be at least two in person meetings between the A/E and the BECxA.
  - BECx Requirements and Functional Performance Testing (FPT) Requirements Specifications: The BECx requirements and FPT requirements are incorporated into the construction documents via BECx and FPT specification section(s) provided by the BECxA and submitted to the A/E for review and approval. The FPT requirements (including both mock-up and field testing) will be incorporated into the construction documents via the BECx Requirements or Functional Performance Testing specification section.

c. Pre-Construction Phase

- i. *Value Engineering Review*: All building enclosure related value engineering options must be reviewed by the BECxA. The BECxA will respond to value engineering (VE) options and identify any associated performance differences between the value engineering option and the base design, including impact on meeting the OPR. If the project team elects to

pursue VE options that are at risk of not meeting the OPR, the OPR shall be updated to reflect realistic performance goals based on the VE option.

- ii. *Reviews of Requests for Information (RFI's) or Architect's Supplemental Instruction (ASI's)*: The BECxA shall review RFI's and ASI's related to the building enclosure. BECxA written comments on RFI's or ASI's shall be provided to the A/E for review and incorporation into the RFI or ASI.  
*BECx Kick-Off Meeting*: The Contractor will arrange and schedule a BECx Kick-Off Meeting, prior to the commencement of the building enclosure mock-up or building enclosure construction, to be chaired by the BECxA. The Contractor is responsible for attendance of all enclosure sub-contractors. Topics covered during the meeting would include, but not necessarily be limited to, contract documents, coordination items, observation and testing procedures, submittals and shop drawings, construction schedule, sequencing, material selection and compatibility, and other construction items.
- iii. *Review of Submittals and Shop Drawings*: The A/E or Contractor shall provide all building enclosure sub-contractor submittals/shop drawings. Submittals and shop drawings to be provided to the BECxA prior to commencement of building enclosure construction. The review of submittals and shop drawings will be for compliance to the contract documents with an emphasis on performance, constructability, transition details and coordination, sequencing, and quality control contractual requirements. All BECxA review comments shall be forwarded, in writing, to the A/E for their review/incorporation and formal response to the Contractor. The BECxA shall include two rounds of reviews for initial submittals and resubmittals (submittals and shop drawings) in the base scope.
- iv. *Coordination Meeting(s)*: The Contractor will arrange and schedule a Pre-Construction Coordination Meeting, prior to the commencement of the building enclosure mock-up or building enclosure construction. The Contractor is responsible for attendance of all enclosure sub-contractors. Topics covered during the meeting will focus on coordination and detailing between enclosure sub-contractors. A single coordination meeting will occur with attendance of all enclosure sub-contractors. Some projects may utilize multiple coordination meetings.
- v. *Mock-up Review*: A stand-alone mock-up is required for Enhanced BECx. Fundamental BECx may utilize in-place mock-ups as required. Mock-ups of the critical enclosure components and interfaces shall be constructed and tested prior to the commencement of building enclosure construction in order to verify the mock-up against the specified performance testing requirements. Components required in the mock-ups will be identified in the relevant sections of the contract documents by the design team. Construction of the mock-up is to be observed and documented by the BECxA. Once completed, the Contractor will provide confirmation of completion to the BECxA and A/E. The completed mock-up will then be reviewed by the BECxA and A/E for compliance to the Contract Documents.  
*Mock-up Testing*: Once the mock-up has been observed for compliance to the Contract Documents, submittals, shop drawings, and manufacturer's installation instruction, the mock-up will be tested to demonstrate compliance to the performance requirements set forth in the Contract Documents. The testing protocol will be followed will be as identified in the Contract Documents in the Functional Performance Test Specification developed by the BECxA and approved by the A/E during the Design Phase. If the specified performance criteria is not achieved during mock-up testing, the Contractor shall investigate the source of the failure and propose a remediation strategy for review and comment by the BECxA and A/E, and install the approved repair work. The mock-up shall be retested until passing results are achieved, prior to commencement of enclosure construction on the building. Any repairs or remedial work performed on the mock-up must be documented by the BECxA. Changes to the design resulting from the mock-up should be confirmed with appropriate documentation from the A/E. Costs for retesting are the responsibility of the contractor.

d. Construction Phase

- i. *Reviews of Requests for Information (RFIs) or Architect's Supplemental Instruction (ASIs):* The BECx shall review RFIs and ASIs related to the building enclosure. BECx written comments on RFIs or ASIs shall be provided to the A/E for review and incorporation into the RFI or ASI.
  - ii. *Owner/Architect/Contractor (OAC) Meetings:* The BECx shall participate, in person or via conference call, in at least one OAC meeting per month generally after BECx activities such as mock-up testing, field testing, or site observation visits.
  - iii. *Building Enclosure Construction Observations:* Upon commencement of building enclosure construction and continuing throughout the construction process, on-site observations will be conducted by the BECx to review the work for compliance to contract documents, approved submittals/shop drawings, manufacturer's installation instructions, and industry standards. Observation logs will be generated by the BECx with responses/resolution tracked with the goal of having zero open items at project completion. The BECx may participate in dispute resolution regarding exterior enclosure components/systems and associated performance. The BECx and the A/E may be relied upon during construction to evaluate compliance with the OPR; to provide and vet out alternative solutions; and to evaluate the associated risks.
  - iv. *Functional Performance Testing:* The BECx shall observe or perform functional performance testing of the building enclosure. The field FPT will be performed as required by the contract documents. If the performance requirements during testing are not achieved, the test specimen should be retested until the specified performance criteria is achieved. Additional testing may be performed as determined by the Owner, BECx, and A/E as outlined in the project specifications.
  - v. *Whole Building Air Leakage Testing:* Whole building air leakage testing shall be performed at the completion of the project. The building enclosure shall exhibit air leakage equal to or less than 0.1 cfm/sf per ASTM E779 for Enhanced BECx. For Fundamental BECx, a less stringent whole building air leakage requirement may be identified and used for whole building air leakage testing, or whole building air leakage testing may not be performed.
  - vi. *BEcx Plan Updates:* The BECx plan will be updated as needed, as this is a living document and may reflect new or modified requirements as directed by the Owner.
- e. Post-Occupancy Phase
- i. *BEcx Record:* The BECx will finalize the BECx plan and the final BECx report with respect to the building enclosure. The initial BECx Record will be provided at completion of the construction phase, and updated after the post-occupancy project review. The BECx Record shall include the following:
    - (001) Executive summary for the project.
    - (002) Summary of the BECx comments from design phase and construction phase that were not addressed/completed by the architect and/or contractor.
    - (003) Construction phase observation log with contractor responses.
    - (004) Summary of lessons learned.
  - ii. *Training:* The BECx provides appropriate training to the building maintenance personnel with respect to building enclosure maintenance.
  - iii. *Post Occupancy Project Review:* The BECx will provide a site review and follow-up meeting ten months post-occupancy to the DFCM project manager. A written post-occupancy site visit report will be incorporated into the Building Enclosure Commissioning Record. Training to the facilities staff can be conducted during the post-occupancy review site visit. *Building Enclosure Maintenance Manual:* The BECx will develop and provide a maintenance manual that includes building enclosure descriptions, product data sheets, and manufacturer's warranties. Manual will define appropriate operating parameters, such as temperature and relative humidity, for the building enclosure and describe the life expectancy as well as required maintenance frequency.
5. **Building Enclosure Performance Guidelines:** The following summarizes general performance guidelines related to water, vapor, air, and thermal. Performance requirements may deviate from the

general recommendations below to suit project needs when approved by DFCM. Appendix E reference documents lists Referenced Standards and Codes which can be applied to the building enclosure functional performance testing planned for the project.

a. General

- i. The building enclosure must be designed and constructed in accordance with all applicable codes and standards.
- ii. The building enclosure shall be defined as the barrier between the conditioned spaces and the exterior environment.
- iii. Building enclosure performance criteria shall be reconciled with the project specific energy model. The OPR shall summarize all building enclosure performance criteria and criteria must be clearly defined or quantitative.
- iv. A minimum of two lines of defense for air and water control is required at building enclosure interface conditions.
- v. The building enclosure must limit the amount of vertical fenestration area to no more than 30% of the above-grade wall area. Spandrel shall be insulated to opaque wall minimum insulation requirements. If Spandrel is not insulated to the opaque minimum insulation requirements it will contribute to the 30% limit.

b. Water

- i. The building enclosure must be designed to control and prevent water penetration into the interior. A continuous water control layer must be utilized with an exterior bulk water shedding element when applicable. A drainage component is required for all concealed water control layer assemblies.
- ii. The building enclosure systems shall be designed such that condensation does not occur interior of the primary water control layer. All enclosure materials including finishes, claddings, membranes, and thermal barriers must be evaluated during design with respect to condensation control for project design conditions (exterior design temperature, interior design temperature, and maximum interior relative humidity).
- iii. Water penetration or condensation shall be defined as any water or wetting of materials interior to the primary water control layer (whether visible or not from the interior).
- iv. Materials exterior of the primary water control layer shall be appropriately weather/water resistant and able to accommodate repetitive wetting and drying cycles.
- v. In general, water testing of the building enclosure shall be performed during the pre-construction and construction phases on the mock-up and the building. Water penetration resistance test pressures when testing in accordance with ASTM E1105/AAMA 501.1 shall be no less than 20% of the maximum structural design pressures. Non-fenestration test specimens such as horizontal or below-grade conditions must be evaluated on a project-specific basis to identify the appropriate level and type of testing.

c. Vapor

- i. A continuous Class I or Class II vapor retarder must be provided at all exterior opaque walls, roofing, below-grade foundation walls and slabs, and slab-on-ground conditions. For projects located in ASHRAE Climate Zone 3, a project-specific evaluation shall be performed to identify vapor retarder requirements for roofing and opaque walls.
- ii. Testing is not required, but visual observations by the BECxA of installed work are required. Enhanced BECx scope projects require vapor barriers to be included in the performance mock-up.

d. Air

- i. A continuous air barrier is required at the building enclosure. Air barrier materials must have an air permeance less than 0.004 cfm/sf per ASTM E2178 and air barrier wall assemblies must have an air leakage rate less than 0.04 cfm/sf per ASTM E2178.
- ii. Enhanced BECx scope buildings shall have a whole building air leakage rate of less than 0.10 cfm/sf per ASTM E779. Enhanced BECx scope buildings that are additions to existing buildings may not require whole building air leakage testing, if determined impractical by the project team based on a project-specific evaluation. Whole building air leakage rate for

Fundamental BECx scope buildings will be identified on a project-specific basis. Projects with operable fenestration throughout the building such as student housing are not required to perform whole building air leakage testing; however, the risks associated with electing to not perform this test should be identified to the project team.

- iii. Vapor permeability of air barriers materials and components must be evaluated and identified for each project. Vapor permeability must be specified to limit wetting of building enclosure materials while allowing drying.

e. Thermal

- i. Thermal insulation must be used to control heat flow across the building enclosure. In general, the thermal insulation must be designed to provide continuous thermal resistance per the minimum applicable energy code requirements and as dictated by project energy performance goals. The effective thermal performance must be reconciled with the project energy model and mechanical engineer.
- ii. The overall thermal transmittance of fenestration and doors that are not within the scope of the standards listed in Sentence (3) shall be determined from:
  - Calculations carried out using the procedures described in the ASHRAE Handbook – Fundamentals, or
  - Laboratory tests performed in accordance with ASTM C 1363, “Thermal Performance of Building Materials and Envelope Assemblies by Means of a Hot Box Apparatus,” using an indoor air temperature of  $21\pm 1^{\circ}\text{C}$  ( $70^{\circ}\text{F}$ ) and an outdoor air temperature of  $-18\pm 1^{\circ}\text{C}$  ( $0^{\circ}\text{F}$ ) measured at the mid-height of the fenestration or door.
- iii. The thermal characteristics of building assemblies other than fenestration and doors shall be determined from:
  - Calculations carried out using the procedures described in the ASHRAE Handbook – Fundamentals, the Building Envelope Thermal Bridging Guide (BCHydro), or ISO 14683: Thermal Bridges in Building Construction – Linear Thermal Transmittance – Simplified Methods and Default Values, or
  - Two or three dimensional thermal modeling, or
  - Laboratory tests performed in accordance with ASTM C 1363: Thermal Performance of building materials and Envelope Assemblies by Means of a Hot Box Apparatus using an average temperature of  $75\pm 1^{\circ}\text{F}$  and a temperature difference of  $71\pm 1^{\circ}\text{F}$
- iv. Conductive materials that bypass the thermal insulation layers result in thermal bridging. Thermal bridging shall be accounted for and mitigated as required to meet project thermal resistance requirements. In general, the project team shall evaluate the building enclosure to identify and account for the following thermal bridging elements with respect to condensation resistance and impact on effective u-factor. The following methodology shall be used to categorize and identify thermal bridging:
  - Clear Field: The heat loss due to thermal bridges uniformly distributed that modify the heat flow of the assembly (area based) and is not practical to account for on an individual basis. Examples include masonry anchors.
  - Fenestration systems with vision glass can be calculated using the NFRC 100 procedure. Spandrels shall be calculated using laboratory testing or three-dimensional modeling.
  - Linear: The additional heat loss along a considerable portion of a building perimeter or height in one dimension Examples include slab edges, balconies, parapets, corner framing, and window perimeter transitions.
  - Point: The additional heat loss from a thermal bridge that are countable points on a building. Examples include three-way corners and structural beam penetrations.

- v. The following items need not be taken into account in the calculation of the overall thermal transmittance of opaque building enclosure assemblies if not required by code or other energy requirements/goals:
- Mechanical penetrations such as pipes, ducts, equipment with through-the-wall venting, packaged terminal air conditioners, or heat pumps.
  - The impact of thermal bridges can be ignored if the expected cumulative heat transfer through these thermal bridges is low that the effect does not change the overall thermal transmittance of the building enclosure by more than 10%.

**C. Deliverables:**

HPBS Project Checklist (Appendix A) and associated required submission information at each project phase milestone, including Building Envelop Commissioning Plan and all subsequent site visit and test reports.

### 5.5.5 Building System Performance / Commissioning

**A. Summary / Intent:** This section establishes the minimum requirements for all State of Utah, DFCM projects. Each project’s mechanical, electrical, plumbing, and envelope systems are to be commissioned to ensure a fully functional building and that the owner’s requirements are met. Additional building systems, e.g. smoke control, renewables, acoustic, security, etc., are to be commissioned as needed on a case-by-case basis. Projects will be commissioned in compliance with the intent of the “Building Commissioning Association’s New Construction Building Commissioning Best Practices”<sup>9</sup> and in accordance with applicable components of “ASHRAE Guideline 0 – The Commissioning Process”<sup>10</sup> and “ASHRAE Standard 202 - The Commissioning Process for Building Systems.”<sup>11</sup> The current IECC code shall be followed if applicable.

**B. Compliance:** Each project must meet the following criteria.

1. Qualifications. The commissioning firm and/or commissioning lead must possess current certification from one of the following nationally recognized organizations and be accredited by the American Standards Institute (ANSI/ISO/IEC 17024).
  - a. Associate Air Balance Council (AABC) Commissioning Group Certified Commissioning Authority (ACG CxA).
  - b. Building Commissioning Association (BCxA) Certified Commissioning Firm (CCF) and/or Certified Commissioning Professional (CCP).
  - c. American Society of Heating, Refrigeration and Air-Conditioning Engineers (ASHRAE) Building Commissioning Professional (BCxP) certification.
  - d. Alternative certifications must be approved by the High-Performance Building Director.
2. Building Complexity. Each project will either receive a Level I or Level II effort of commissioning. The level will be determined by the size, construction, budget, complexity, and intended use of the building.
  - a. The level of commissioning, including variations from these requirements, is to be approved by the DFCM Building Performance Program Director.
  - b. The following complexity schedule is based on the Schedule of Architectural Project Complexity<sup>12</sup> contained within the document “Division of Facilities Construction and Management Architectural/Engineering/High-Performance Building Fees” effective date: December 12, 2017.
    - i. *Schedule A Projects:* All new construction and renovations to be Level 1.
    - ii. *Schedule B Projects:* All new construction and renovations less than \$10M to be Level 1; greater than \$10M to be Level 2. Unoccupied buildings, e.g. parking garages, storage, etc. to be Level 1.
    - iii. *Schedule C Projects:* All new construction and renovations less than \$10M to be Level 1; greater than \$10M to be Level 2.
    - iv. *Schedule D Projects:* All new construction and renovations less than \$5M to be Level 1; greater than \$5M to be Level 2.
    - v. *Schedule E Projects:* All new construction and renovations less than \$5M to be Level 1; greater than \$5M to be Level 2.  
Mechanical system-oriented renovations less than \$5M to be considered on a case-by-case basis, approved by the High-Performance Building Director.
3. Pre-Design / Design Phase Commissioning Requirements.
  - a. **Design Cx Kick Off Meeting.** CxA shall provide the project team a review of the commissioning process including roles, responsibilities, deliverables, milestones, etc., prior to the end of schematic design. (Not required for Level 1.)

<sup>9</sup> [https://www.bcxa.org/wp-content/uploads/2016/03/BCxA.NCCx-BestPractices\\_031616.pdf](https://www.bcxa.org/wp-content/uploads/2016/03/BCxA.NCCx-BestPractices_031616.pdf)

<sup>10</sup> [https://webstore.ansi.org/Standards/ASHRAE/ASHRAEGuideline2019SPANISH?gclid=EA1aIQobChMI0OeF\\_JvU5gIVmB6tBh2WygJMEAAVASAAEgLTu\\_D\\_BwE](https://webstore.ansi.org/Standards/ASHRAE/ASHRAEGuideline2019SPANISH?gclid=EA1aIQobChMI0OeF_JvU5gIVmB6tBh2WygJMEAAVASAAEgLTu_D_BwE)

<sup>11</sup> [https://www.techstreet.com/ashrae/standards/ashrae-202-2018?product\\_id=2025517](https://www.techstreet.com/ashrae/standards/ashrae-202-2018?product_id=2025517)

<sup>12</sup> <https://dfcm.utah.gov/wp-content/uploads/AE-Fee-Schedule-12-12-2017.pdf>

- i. *Owner's Project Requirements (OPR)*. CxA shall assist the design team, DFCM and owner in developing the OPR as it relates to the building systems, prior to the end of schematic design (or as defined above, program section) CxA shall ensure alignment of the OPR with DFCM Standards and/or state agency or institutional requirements.
- b. Schematic Design and/or Basis of Design Review. CxA shall review and provide comments related to the OPR, operational performance, constructability, function, systems integration, access, etc. (Not required for Level 1.)
- c. Systems Selection. CxA shall participate in ongoing building systems selection meeting(s). Provide input related to the OPR. (Not required for Level 1.)
- d. Design Development Review. CxA shall review and provide comments related to the OPR, operational performance, constructability, function, systems integration, access, etc.
- e. Utility Incentives Review. CxA shall review the design team's efforts to ensure the design maximizes current Rocky Mountain Power and Dominion Energy incentive opportunities on life-cycle cost-effective energy efficiency measures. Coordinate with Energy Management team for campus projects to determine applicability.
- f. Controls Review Meeting. CxA shall review proposed controls strategies as they relate to the OPR and the owner's operational practices. Ensure participation of the owner's building operators, controls contactors (when possible), and engineering team. (Not required for Level 1).
- g. Systems Integration Meeting: The CxA shall review with the design team as they relate to control and monitoring strategies between trades within the design and identify any scope overlaps.
- h. Training. CxA shall ensure design team's training requirements address the following:
  - i. Purpose of equipment.
  - ii. Operational instruction and procedures.
  - iii. Overview of related systems.
  - iv. Emergency instruction and procedures.
  - v. Troubleshooting procedures.
  - vi. Proper/improper function indicators.
  - vii. Preventative maintenance and inspections procedures.
  - viii. Training materials reporting and recording requirements.
  - ix. Instructor qualifications.
- i. Preliminary Cx Plan. CxA shall provide a preliminary Cx Plan that begins to align the Cx process with the OPR and design. The Cx plan shall include the following at a minimum:
  - i. Cx process overview
  - ii. Roles and responsibilities of project team members
  - iii. Communication Protocols
  - iv. Milestones and project phasing
  - v. Construction Process
    - (001) Design Reviews
    - (002) Submittal Reviews
    - (003) On-site Observations
  - vi. Cx Deliverables
  - vii. Pre-Functional Tests (Samples)
  - viii. Functional Performance Test (Samples)
  - ix. Warranty reviews
  - x. Seasonal testing (deferred)

- j. Commissioning Specifications. CxA shall provide a description of the Cx process, communication, milestones, including roles/responsibilities of project team members for incorporation into the contract documents, for all divisions and phases that require commissioning.
4. Construction Documents Review. CxA shall review and provide comments related to the OPR, BOD, operational performance, constructability, function, systems integration, access, etc. Review comments not addressed or incorporated by the design team and corresponding design team comments, are to be documented in the Cx record.
  5. Construction Phase Commissioning Requirements
    - a. Submittal Review. CxA shall review all related shop drawings and submittals for commissioned equipment or systems. The review should address constructability, sequencing, performance, function, durability, and related systems interface.
      - i. Deviations from the OPR must be recorded.
      - ii. Provide review comments concurrently to the design team's submittal review. Reviews provided after the design team are prohibited, unless dictated by unforeseen circumstances.
      - iii. Review comments not addressed or incorporated by the design team and corresponding design team comments, to be documented in the Cx record.
      - iv. Sampling approach for the submittals review is prohibited.
      - v. Submittal review log shall be kept current and distributed to the project team.
    - b. Substitutions Requests and Contract Modifications. CxA is to review proposed substitution requests, ASIs, proposed change orders, and change orders as they relate to the functional performance of the building systems as required by the OPR. (Not required for Level 1).
    - c. Utility Incentives. CxA shall review submittals to ensure submitted equipment and systems of the design team's energy efficiency measures comply with utility incentive requirements.
    - d. Owner's Project Requirements. CxA will take over the OPR and BOD at the beginning of construction. From this point, the CxA will update and finalize the OPR to reflect changes from bidding, value engineering, submittals, schedule, etc.
    - e. Final Commissioning Plan. The CxA shall revise the Commissioning Plan based on approved submittals, with revisions to the step-by-step narrative test procedures. This will be issued to the Project Team for use. The following at a minimum shall be included:
      - i. FPT testing forms shall be provided for the project team to review prior to testing.
      - ii. *Performance Prerequisites:* 100% testing and verification of major systems (e.g., central plant equipment, AHUs, boilers, pumps, cooling towers, chiller, ERVs, etc.), building level utility meters and applicable sub-metering is required.
      - iii. A minimum initial 20% testing and verification of terminal equipment (e.g. VAVs, FCUs, CUHs, UHs, etc.), or as required per project requirements.
      - iv. 100% testing and verification of major electrical systems (e.g., emergency generators, automatic transfer switches, load shedding equipment, etc.), is required
      - v. A minimum initial 20% testing and verification major electrical systems (e.g. electrical panelboards, lighting controls, etc.).
      - vi. Retesting shall occur at a rate defined by the CxA in the specifications.
      - vii. All completed testing documentation shall be provided in the Cx Report.
    - f. Cx Kick Off Meeting. CxA shall facilitate an in-person meeting for the project team with a review of the Cx process; including roles, responsibilities, deliverables, schedule, OPR, and milestones.
    - g. Commissioning Coordination Meetings. CxA shall facilitate periodic coordination meetings to review the commissioning effort with the project team. Issues to be reviewed include sequencing, constructability, testing, schedule, field issues, resolutions, etc.. Frequency shall be recommended by the CxA as determined by the building complexity and project schedule.
    - h. Site Inspections. CxA shall provide periodic site inspections of current installation efforts. Frequency shall be recommended by the CxA as determined by the building complexity and project schedule. Field report shall be issued to the project team within five business days.

- i. Sequence of Operations (SOOs) Integration Meeting. CxA shall review and facilitate a sequence integration meeting with the owner, design team and control contractors to identify any gaps from the control submittal and resolve issues with design intent (OPR).
- j. Flushing and Cleaning. CxA shall review the flush plan and ensure that proper flushing and clean procedures are implemented and followed per manufacturer's recommendations. The CxA may verify onsite if required.
- k. Pre-Functional Testing (PFT). CxA shall develop and provide PFT checklists for the contracting team based on accepted systems and equipment. The CxA shall field verify 20% of equipment and systems to ensure accuracy of PFT forms. Verify completion and provide necessary documentation.
- l. Start Up Testing. CxA shall review the contracting team's completed start-up forms to ensure start-up procedures per manufacturer's recommendations. The CxA shall be present for major equipment start-up with the manufacture present and associated contractors.
- m. Test and Balance. The CxA shall coordinate test and balance witnessing to be reasonably confident that the work is being done correctly. Review Test and Balance preliminary report prior to functional performance testing.
- n. Functional Performance Testing (FPT). CxA shall provide final FPT procedures to the design and contracting team for review prior to testing efforts.
  - i. Test procedure shall confirm that every sequence in the building automation system sequence of operation and relevant features and sequences of on-board controllers including staging, interlocks with other equipment, alarms, safeties, manual operation, schedules, loss of power, fire mode and failures, etc. (life-safety at critical facilities shall be individually tested)
  - ii. Provide functional test to the contractors early, so they can execute the tests on their own prior to formal witness functional testing.  
Testing procedures shall follow the Cx specifications and align with the approved systems. The project team shall be notified when alternative testing procedures are planned.
- o. Point to Point. CxA shall review contracting team's point to point testing documentation of the all systems.
- p. Substantial Completion. CxA shall provide the owner a list of outstanding commissioning-related issues for incorporation into the overall project punch list.
- q. Operations and Maintenance Manual Review. CxA shall facilitate a review of the O&M manuals, concurrent with the design team, to ensure all systems and equipment have the proper manuals, submittals, and shop drawings, per the OPR and construction documents.
- r. Final As-Built Drawings. The CxA shall confirm that the as-built drawings for specified systems have been submitted. The CxA is not required to verify accuracy, however it is recommended that the CxA facilitate an owner's review of the as-builts for accuracy.
- s. Systems Manual. The CxA shall compile the project systems manual should consist of the following:
  - i. Executive Summary
  - ii. Design narrative
  - iii. Owner Project requirements
  - iv. Basis of Design
  - v. Sequence of Operations
  - vi. Setpoint manual for all commissioned systems, which should include design, actual, and trending setpoints
  - vii. Operational Procedures
    - (001) Normal
    - (002) Emergency
  - viii. Systems schematics (one lines)
  - ix. Final TAB report
  - x. Final occupancy schedules
  - xi. Seasonal adjustment recommendations
  - xii. Recommissioning/ongoing Cx recommendations by equipment type
  - xiii. Recommended Maintenance procedures, schedules
- t. Training. CxA shall review submitted training agendas to ensure that the training is sufficient,

relevant, comprehensive, and inclusive of connected systems per the OPR and construction documents.

*Training Evaluation.* CxA shall administer a training evaluation based upon ASHRAE 0-2013 Appendix P. Results shall be reported to the owner.

6. Warranty Phase Commissioning

- a. Utility Incentives. CxA shall gather the final utility incentive documentation and complete construction related efforts, when required by incentive requirements.
- b. Trending. Each system and major piece of equipment shall be trended for a period of time determined by the Engineer of Record and verified by the CxA. Any changes for testing purpose will be conveyed to the owner. Ideally, the FDD system will be used for this purpose.
- c. Deferred Testing. CxA shall provide deferred testing on equipment and systems unable to be fully commissioned during initial FPT, such as equipment that operates seasonally.
- d. Commissioning Final Report. CxA shall provide a Cx report within three months of substantial completion, per current energy codes. The final, amended Cx report, shall be provided within one month of the final warranty walk. The following sections shall be included:
  - i. Executive summary
  - ii. Unresolved issues
  - iii. Design reviews
  - iv. Submittal reviews
  - v. Startup reports
  - vi. Completed Commissioning Forms
  - vii. Issues log
  - viii. Cx meeting minutes
  - ix. Electrical systems testing reports
  - x. OPR
  - xi. Seasonal testing results
- e. Equipment Data Profiles. CxA shall provide and/or gather the equipment profile data, per Appendix F, within three months of substantial completion.
- f. Lessons Learned Summary. CxA shall provide the project team a summary of the lessons learned to be referenced on future projects. The summary shall address each phase (i.e., design, construction, operations and each system i.e., mechanical, electrical, plumbing, etc.). The summary shall be provided to all project team members.
- g. Maintenance System. The CxA shall work with facilities and assist the staff to integrate the equipment into the owners CMMS system.
- h. Warranty Meeting (For all commissioning projects). Conduct a Warranty meeting ten months after substantial completion, which includes the following:
  - i. A meeting with facility management staff, a representative from the design team and a representative from the General Contractor. The agenda shall include but is not limited to:
    - (001) Seasonal testing review
    - (002) Review of any open issues from the commissioning process
    - (003) Discussion of building operation, potential warranty issues, support needed.
    - (004) Review energy performance of the facility compared to design targets.  
Review meter data to verify accuracy and provide training to facility staff to access meter data as needed.
    - (005) Walk through the facility to observe operation
  - ii. After the meeting, the commissioning agent will issue an addendum to the commissioning report documenting the ten month review.
- i. Post Occupancy Follow-up (For all Level II commissioning projects). In addition to the warranty meeting, the CxA shall complete the following:
  - i. Frequency:

- (001) Every quarter for the first year of operation for buildings of Schedule A, B, and C.
  - (002) Monthly for the first two years of operation for buildings of Schedule D and E.
  - ii. Create and deliver a quarterly report summarizing the results of the fault detection and diagnostic system, the report should include at a minimum:
    - (001) Building energy performance
    - (002) Key Performance Indicators including but not limited to: Source EUI, target, and associated emissions (CO<sub>2</sub>, SO<sub>2</sub>, NO<sub>x</sub>)
    - (003) Top five issues that need to be addressed
    - (004) Documentation of resolved issues
  - iii. Facilitate a meeting with facility management staff, a representative from the design team and a representative from the General Contractor. The agenda shall include but is not limited to:
    - (001) Review of the quarterly report
    - (002) Review of the top five issues
    - (003) Q&A from the staff
    - (004) Training tips on the use of the FDD tool
- C. HPBS Project Checklist (Appendix A) and associated required submission information at each project phase milestone, including Building Commissioning Plan and all subsequent site visit and test reports.

## 5.5.6 Metering

- A. **Intent:** Provide a complete building utility metering system that consolidates metering information for all building systems including power, domestic water, irrigation water, chilled water, heating water, steam or condensate, natural gas, propane or any other similar building utility system and makes the metering information readily and easily available for Users and Owner to review, report and trend from the metering head-end system.

[See UFacilities Metering Guidelines, which are published on the UFacilities website \(https://pdc.utah.edu/aec/#design\\_resources\).](https://pdc.utah.edu/aec/#design_resources)

### B. Compliance

#### 1. General Metering Requirements

- a. All meters shall be clearly identified on single-line diagrams, schematic plans and utility site plans.
- b. Meters shall be digital based meters that shall be connected to a single head-end for the building and/or campus (where applicable), the metering system head-end shall either utilize the building automation system or an equivalent centralized metering system.
- c. Projects that are part of a campus or associated with an existing building shall have metering systems that are coordinated with the campus and/or existing building metering systems to ensure compatibility and compliance with their specific metering requirements.
- d. Meters and metering systems shall provide full capability and accessibility to all required data points at the metering system head-end and shall include remote network accessibility.
- e. Metering head-end shall include complete programming graphical metering pages to display: data points, weekly trends, monthly trends, yearly trends. The metering head-end shall also include programming for reporting and exporting of metering information as a CSV or compatible format.
- f. CxA team to include commissioning and testing of metering head-end system along with Owner training to ensure metering system is fully functional and all metered information is reporting correctly.
- g. For all water or gas meters, provide a strainer upstream meter. Provide a bypass around applicable meters that are installed inline. Bypasses are not required for insertion turbine meters that can be removed from the pipeline for maintenance without interrupting flow. Provide a test port downstream of meters.

- h. If individual pieces of equipment have internal metering capabilities that meet the requirements of this section, these points can be mapped into the meter monitoring network in lieu of external submeters.
- i. Meters shall report real time results in 15-minute intervals.

## 2. Electric Power Metering Requirements

- a. Provide main building metering of each service and/or main building feeder (if building or structure is part of a campus primary utility fed system).
- b. Exception: A building or structure sub-fed from another building or structure with an electrical load of 100kW or less does not require a separate meter provided that the building or structure it is fed by has metering complying with the metering standard.
- c. For each building or structure where the electrical load exceeds 500 kW, provide sub-metering of individual equipment loads that exceed 100 kW. Sub-metering of these systems and/or individual loads that exceed 100 kW may utilize integral equipment metering capabilities provided they meet the requirements of this metering section.
- d. Provide sub-metering of all prime generation system such as photovoltaic generation systems, wind generation system, cogeneration systems. Standby systems such as standby/emergency generators do not require sub metering.
- e. Main building meter(s) shall comply with ANSI C12.20 0.2% accuracy class with corresponding revenue grade instrument transformers and shall include digital displays capable of displaying all metering values.
- f. Sub-meters shall comply with ANSI C12.20 0.5% accuracy class with corresponding revenue grade instrument transformers.
- g. Meter(s) shall include metering of the following: energy total and per phase, power (demand) total and per phase, power factor total and per phase, voltage line-line and line-neutral, current total and per phase.

## 3. Domestic Water Metering Requirements

- a. Provide meter for domestic water usage on any project consuming domestic water. Irrigation usage should always be provided with a separate meter. Select meter type suitable for the flow range of the project (positive displacement, orifice, venturi, turbine, vortex shedding, ultrasonic). Flow meter shall be sized based on expected flow range and not on pipe size.
- b. Output. Meter shall provide the following data: Volume (Gallons, Cubic Feet) and flow rate.
- c. Accuracy shall be  $\pm 2\%$  over the published flow range of the meter.

## 4. Chilled and Heating Water Metering Requirements

- a. For buildings that receive chilled or heating water from a source not dedicated to that building provide a BTU meter. BTU meter shall be packaged meter that can read flow, supply and return temperatures, and communicate using BACnet. Select meter type suitable for the flow needs of the project. Ensure meter type is compatible with anticipated temperatures with 20% safety factor.
- b. Output. Meter shall provide the following data: Flow (GPM), Supply Temperature (F), Return Temperature (F).
- c. Accuracy shall be  $\pm 2\%$  over the published flow range of the meter

## 5. Steam and Condensate Metering Requirements

- a. Buildings that receive steam from a source not dedicated to that building shall be fitted with either steam or condensate meters. Vortex-type mass flow meters are preferred. Steam meters shall have integral temperature and pressure (density) compensation. Condensate meters shall be positive displacement. Ensure meter type is compatible with anticipated temperatures with 20% safety factor.
- b. Output. Meter shall provide the following data: Mass Flow (lb/hr) – Steam, Flow (GPM) – Condensate

- c. Accuracy. Ensure steam meters are sized to provide a suitable range of accuracy (turndown ratio). Accuracy shall be  $\pm 2\%$  over the published flow range of the meter.
6. Natural Gas and Propane Metering Requirements
- a. Provide meter for natural gas or propane on any project consuming natural gas or propane gas. Propane tanks smaller than 250 gallons do not need to be metered. Select meter type suitable for the flow range of the project. Flow meter shall be sized based on load, pressure, and pressure drop.
  - b. Output. Meter shall provide the following data: Volumetric Flow Rate (Cubic Feet Hour)
  - c. Accuracy shall be  $\pm 2\%$  over the published flow range of the meter
- C. Additional Resources – Renovations: Renovation projects are not required to comply with metering requirements unless 50% or more of a system are being changed. For example if a natural gas system has a total load of 1,000 MBH and was getting a new 399 MBH boiler, compliance with meter requirements would not be required.
- D. Deliverables: HPBS Project Checklist (Appendix A) and associated required submission information at each project phase milestone.

### 5.5.7 Fault Detection and Diagnostics Software

- A. Fault Detection and Diagnostic (FDD) Software will be required on all new facilities as follows:
1. For All Facilities:
    - a. FDD will be deployed prior to functional testing and utilized during the functional testing process.
    - b. FDD will be deployed using a cloud based solution with the following exceptions:
      - i. Facility security requires an on-premise deployment
      - ii. An on-premise deployment already exists at that location or campus
    - c. FDD will be limited to collecting 15 min interval utility meter data. Utility data includes:
      - i. Electricity
      - ii. Natural Gas
      - iii. Domestic Water
  2. For all facilities that require Level II commissioning and are on Schedules A, B, and C:
    - a. In addition to the requirements listed under 5.5F.1.A, the following is required:
      - i. Connection to all major pieces of equipment at the facility including:
        - (001) Air handling units
        - (002) Roof top units
        - (003) Hot water plants (Boilers, Pumps, etc)
        - (004) Chilled water plants (Chillers, pumps, etc.,)
        - (005) Terminal equipment (VAV boxes, fan coils, etc)
      - iv. The FDD system should include all licensing for the first two years of operation.
      - v. The FDD system should have analytics capable of evaluating the performance of the equipment listed above every 15 minutes.
      - vi. The FDD system should be implemented under the CxA scope of services
  3. For all facilities that required Level II commissioning and are on Schedules D and E:
    - a. In addition to the requirements listed under 5.5.7 the following is required:
      - i. Connection to all major pieces of equipment at the facility including terminal units (VAV boxes, Fan coil units, etc.,)
      - ii. The FDD systems should include a building dashboard that provides the following minimum information:
        - (001) Real time energy performance compared to baseline. Baseline options include:

- First year of operation
  - Similar DFCM managed facilities
- (002) Key Performance Indicators including but not limited to Source EUI, target, and associated emissions (CO<sub>2</sub>, SO<sub>2</sub>, NO<sub>x</sub>)

## B. Data Points

1. Refer to Appendix F for the DFCM standard Tagging convention.
2. The labels used in Appendix F have the following definitions:
  - a. Description: This column is a description of what the control point represents.
  - b. Control Point Name (navName): This is the name of the control point in the building automation system.
  - c. Tags: This column shows the keywords associated with each point, these determine which queries will find these points, which rules will run on each point, and so on.
  - d. Point type: This column describes the type of data the point will contain. Options include: Boolean and numeric. If numeric (Num) significant digits are specified by the following number. Examples:
    - i. Num, 1 = 5
    - ii. Num, .01 = 0.05
  - e. UofM: This column contains the unit of measurement of the point. These may include kWh, Hz, On/Off, %, etc.
  - f. History: Specified the trend interval required. Options include: Change of Value (COV) and interval (Int). The time interval that applies to the COV period or INT and is specified by the following number. Examples:
    - i. Int, 10 min – trend at 10 minute intervals
    - ii. COV, 24hrs – trend COV over a 24 hr period

- C. Deliverables: HPBS Project Checklist (Appendix A) and associated required submission information at each project phase milestone.

### 5.5.8 Efficient Equipment Purchasing

- A. Summary / Intent:** Purchase appliances and equipment that enhance ongoing energy reduction efforts through efficient energy utilization.
- B. Compliance:** All applicable appliances, equipment, products, and/or furnishings shall meet one or more of the following criteria
3. ENERGY STAR Qualified<sup>13</sup>
  4. EPACT Registered<sup>14</sup>
  5. Products that meet or exceed the US Department of Energy's FEMP Energy Efficiency Recommendations<sup>15</sup>
  6. Utility company incentive/rebate approved equipment (various sources)
- C. Deliverables:** HPBS Project Checklist (Appendix A) and associated required submission information at each project phase milestone.

---

<sup>13</sup> <https://www.energystar.gov/products?s=mega>

<sup>14</sup> [https://epact.energy.gov/pdfs/standard\\_compliance.pdf](https://epact.energy.gov/pdfs/standard_compliance.pdf)

<sup>15</sup> <https://www.energy.gov/eere/femp/energy-efficient-products-and-energy-saving-technologies>

## 5.6 Material Impact Reduction

### 5.6.1 Summary / Intent

- A. To reduce the amount of waste taken to the landfill over the life of the building.
- B. To reduce the negative environmental impacts associated with building material extraction, manufacturing, transportation, and landfilling.

### 5.6.2 Compliance

- A. Complete Appendix G (material tracking and information worksheet) throughout project and submit to the Building Performance Program Director at substantial completion.
- B. Ongoing Building Recycling
  - 1. All State facilities shall have material recycling infrastructure. This includes, but is not limited to:
    - a. Provide designated areas in public spaces, break rooms and dining areas for waste and recycling bins.
    - b. Offices, classrooms, workrooms, and print rooms shall all have designed areas for mixed paper recycling.
    - c. Provide appropriate dumpsters or waste bins within the exterior enclosure for recycling materials.
  - 2. Mixed paper, plastic, and mixed metals recycling shall be provided. If one or more of these materials is not recycled in the community, a variance request shall be provided to the DFCM Building Performance Program Manager.
- C. Water bottle filling stations shall be provided at all drinking fountains. Specify water bottle filling stations with the drinking fountains in the project specifications.
- D. Construction Waste Management
  - 1. Recycle 75% of the construction waste, by weight or volume.
  - 2. Include a waste management section in the project specifications, outlining the recycling standard and waste management plan requirements, including the communication strategies and standards to be upheld through the construction.
  - 3. Contractor to track construction waste recycling and provide a waste stream summary report and compliance letter to DFCM with project close-out documentation.
- E. Construction Material Air Quality Impact Reduction
  - 1. Identify and specify building materials that are both extracted and manufactured within 500 miles of the project site. Only the value associated with the regional content, by percentage, shall contribute to the sustainable value of the product.
    - Key materials include concrete, concrete masonry, brick, stone, gypsum board, steel joists, and regionally manufactured misc. metals.
  - 2. Identify and specify building materials that contain recycled materials. Only the value associated with the recycled, by percentage, shall contribute to the sustainable value of the product.
    - a. Recycled content shall be tracked as both pre-consumer and post-consumer recycled content. Only 50% of the value of the pre-consumer recycled content shall contribute toward the sustainable value of the product.
    - b. Only the value associated with the recycled content shall contribute to the sustainable value of the product.
      - Key materials containing recycled content include concrete, all metal containing materials, plastic containing materials, carpet, and suspended ceiling systems.
  - 3. 35% of building materials, by value, shall meet the regional and/or recycled content thresholds.

4. Identify key materials that shall meet a regional or recycled material threshold within the project specifications.
5. Contractor to track regional and recycled content in construction materials using the DFCM HPBS Appendix G.

**F. Material Durability**

1. The project shall be designed to meet the owner's expectations for building life span. The majority of buildings constructed, operated and owned by the State of Utah are anticipated to have a 100 + year life. Within these buildings, the building systems are anticipated to achieve the following life spans prior to replacement:
2. Building Structure: Lifespan of the building designed to meet the seismic requirements set forth in relevant section of the DFCM Design Requirements.
  - a. Exterior Building Cladding: 50 + Years
  - b. Aluminum Window System: 25 Years
  - c. Membrane Roof: 20 Years
  - d. Metal Roof: 40 Years
  - e. Mechanical Systems: 20 Years
  - f. Plumbing Systems: 30 Years
  - g. Electrical Accessories, Lighting, and Controls: 10-30 Years
3. Materials with a useful lifespan of less ten years or less shall be 100% recyclable, at the end of their life. These materials may include, but are not limited to carpet, appliances and equipment, and furniture systems. Any material that is on a replacement cycle of less than ten years, based on DFCM facility maintenance standards falls under this requirement.
4. At the completion of construction, a list of building systems and anticipated life spans shall be submitted to DFCM with the project closeout documents to be incorporated into the State Asset management software. Specific recycling instructions for materials with an anticipated life span of less than ten years shall be provided in the Operations and Management documentation.

**5.6.3 Deliverables:** HPBS Project Checklist (Appendix A) and associated required submission information at each project phase milestone. Completed Appendix G.

## 5.7 Occupant Wellness

**5.7.1 Summary / Intent:** Work environments that prioritize occupant health and wellbeing enhance productivity, reduce absenteeism and turnover, and improve overall employee satisfaction.

**5.7.2 Compliance:** The Contractor shall submit an Indoor Air Quality Plan during the submittal phase, outlining the implementation strategies to achieve the SMACNA requirements as well as the pre-occupancy air quality plan. The contractor shall provide a compliance letter to DFCM with project close-out documentation.

### A. Indoor Air Quality – Building Design

1. All janitor's closets, print and copy rooms, and chemical storage spaces shall be directly exhausted to the exterior and constructed with a hard ceiling or walls sealed to deck. These spaces shall also have doors with closers.
2. Provide permanently installed entryway systems, regularly maintained walk-off mats, or a combination of the two systems. All entry carpets shall be at least 10' in length at primary entryways.

### B. Indoor Air Quality – Construction Materials

1. All interior paints and coatings shall meet the low emitting materials standards set forth by the State of Utah Administrative Rule R307-361. Architectural Coatings<sup>16</sup>.
2. All adhesives and sealants shall meet the low emitting materials standards set forth by the State of Utah Administrative Rule R307-342. Adhesives and Sealants<sup>17</sup>.
3. All flooring systems shall be low emitting, demonstrating compliance by meeting the Green Label Plus program, FloorScore, Greenguard, or the Greenguard low emitting requirements, as applicable, based on the flooring type.
4. Identify key materials that shall meet low emitting material standards within the project specifications.
5. Contractor to track VOC content and low-emitting testing standards using the HPBS Tracking Spreadsheet and submit the completed spreadsheet and a compliance letter to DFCM with project close-out documentation.

### C. Indoor Air Quality – Construction Management

1. Implement an indoor air quality management plan that meets the SMACNA IAQ Guidelines for Occupied Buildings Under Construction, 2nd edition ANSI/SMACNA 008–2008 requirements.
2. Implement a pre-occupancy air quality plan.
3. At the end of construction, prior to occupancy, conduct a building flush-out or an air quality test per USGBC LEED v4.1 Construction Indoor Air Quality Assessment requirements<sup>18</sup>.
4. Provide specifications defining the requirement for an Indoor Air Quality Management Plan during construction.

### B. Indoor Air Quality

1. Hazardous Waste Management: Minimize hazardous waste on-site. The project users should conduct an assessment of cleaning materials, maintenance materials and any chemicals used within the building to determine opportunities to replace hazardous materials with water-based or less hazardous materials. If hazardous materials will continue to be used within the building, a hazardous material storage plan shall be created during the early design phase, and space defined to safely house the hazardous materials before use, as well as after use, prior to pick up.

---

<sup>16</sup> : <https://rules.utah.gov/publicat/code/r307/r307-361.htm>

<sup>17</sup> : <https://rules.utah.gov/publicat/code/r307/r307-342.htm>

<sup>18</sup> <https://www.usgbc.org/node/2614245?return=/credits/new-construction/v4/indoor-environmental-quality>

2. The need for hazardous materials shall be included in the OPR, and the design team shall provide a summary of hazardous material response design strategies within the project basis of design, and submit with all design submissions.
3. Green Cleaning Program: All cleaning materials must comply with the Utah Administrative Rule R307-304. Solvent Cleaning<sup>19</sup>. Additionally, a green cleaning program should be developed and maintained by the owner.

#### E. Daylight and Views

1. 65% of all regularly occupied spaces shall either have direct access to daylight and views or indirect access through shared glazing systems at interior partitions. Regularly occupied spaces are all spaces that are occupied for more than one hour at a time. These include, but are not limited to offices, open offices, conference rooms, classrooms, laboratories (unless specifically needed to be darkened), meeting rooms, etc. A complete list of spaces considered regularly occupied has been developed by the USGBC.  
20
2. A summary of spaces with access to daylight and views and daylight enhancing design strategies within the project basis of design, and submit with all design submissions.

#### F. Environmental Controls

##### 1. Lighting Control

- a. Provide task lighting, or the ability to add task lighting at all individual workstations.
  - b. Provide lighting controls in all conference rooms, classrooms, meeting rooms and other group collaboration spaces to enable both discussions and presentations to occur. This may be dimmable lighting, or preset scenes, as appropriate for the space.
2. Thermal Comfort: Provide a minimum of one thermostat for every individual office, and one thermostat in all conference rooms, classrooms and meeting rooms that have a capacity for more than ten people.
  3. Internal Shades: Provide an internal roller shade at all exterior windows within regularly occupied spaces.
  4. Lighting Quality: Use LED lamps with a CRI of 80 or greater and direct/indirect lighting within all regularly occupied spaces.

#### G. Health and Productivity: To promote the health and wellbeing of staff, the project team shall define a minimum of four strategies that improve employee health and productivity<sup>21</sup>. These strategies may include, but are not limited to:

1. Provide ergonomic workstations with adjustable seating and height adjustable desks for all full-time staff.
2. Provide enhanced break room spaces with access to daylight and views, filtered water, and a place for respite while eating.
3. Integrate one more open, engaging, central stairs to encourage the use of stairs in lieu of elevators for vertical circulation within the building.
4. Provide a staff fitness area with a minimum of three cardio options (such as treadmills, elliptical, or stair machines), weight training equipment and an area for stretching. Locate this area near showers and change rooms.

---

<sup>19</sup> <https://rules.utah.gov/publicat/code/r307/r307-304.htm>

<sup>20</sup> <https://www.usgbc.org/resources/examples-regularly-occupied-spaces-include-following>.

<sup>21</sup> <https://v2.wellcertified.com/v/en/overview>

5. Provide a personal health room on each level of the building. These spaces should include a sink and under-cabinet fridge as well as a comfortable chair for lactation, and meditation friendly flooring.
6. Provide outdoor spaces for physical fitness such as a walking path and/or outdoor fitness equipment.
7. Integrate indoor plants in common spaces as a biophilic design strategy. Provide an ongoing maintenance plan for these interior plants.

### **5.7.3 Deliverables:**

HPBS Project Checklist (Appendix A) and associated required submission information at each project phase milestone. Completed Appendix G.

## **5.8 Education And Outreach**

### **5.8.1 Summary / Intent**

To educate building users and visitors on the sustainable design and construction strategies incorporated into the project, and to enhance awareness of the impact occupant behaviors have on building performance over time.

### **5.8.2 Compliance**

#### **A. User Education and Outreach**

1. Using the provided Building Education Template, create a minimum of three digital signs outlining the key sustainable design and construction goals and strategies. At a minimum, these signs shall address:
  - a. Building energy utilization
  - b. System performance and durability
  - c. Occupant health and comfort
2. Provide a minimum of one sign providing ongoing behaviors and strategies for building staff and occupants to improve building performance and reduce the ongoing environmental impacts of the building. This sign may address electronics and appliance use, thermal and lighting controls, wellness opportunities, ongoing waste management, etc.
3. These digital signs shall be displayed on a flat panel display near the public building entry. If the facility is not accessible to the public, locate these digital displays on the website of the associated State Agency.
4. Include the requirements for User Education and Outreach in the project specifications.

#### **B. Facilities Management Education**

1. The contractor and sub-contractors shall provide the required building system and operational training to the facilities management team and provide digital operations and maintenance manuals for all energy using and warranted systems. This training shall begin with monthly walk-throughs (coordinated by commissioning agent) during construction to enable the facilities team to understand the system design, configuration and installation prior to the installation of ceilings and other finishes.
2. A video of the mechanical and electrical system installation prior to finishes shall be provided as a component of the project close-out documentation.
3. Training shall continue on a monthly basis through testing, balancing and commissioning to ensure optimal understanding of the building system operations and control system operations and set points.
4. Include the requirements for Facilities Management Education in the project specifications.

### **5.8.3 Deliverables:**

HPBS Project Checklist (Appendix A) and associated required submission information at each project phase milestone. Completed Appendix G.

## **5.9 Additional Resources**

- 5.9.1** HPBS Project Checklist (Appendix A)
- 5.9.2** OPR Template (Appendix B)
- 5.9.3** HPBS Workshop Agenda Template (Appendix C)
- 5.9.4** Building Performance: EUI Targets and Energy Modeling Form (Appendix D)
- 5.9.5** Envelop Commissioning Matrix (Appendix E)
- 5.9.6** Analytics Points and Tagging (Appendix F)
- 5.9.7** Material Tracking and Information worksheet (Appendix G)
- 5.9.8** Digital Signage Template
- 5.9.9** Variance / Special Circumstance Form (SB still to create)
- 5.9.10** State Space Use and Utilization Standards
- 5.9.11** Digital Workplace Teleworking Guide

## **5.10 References**

- 5.10.1** <https://comnet.org/>
- 5.10.2** ANSI/ASHRAE Standard 105-2014, Standard Methods of Measuring, Expressing, and Comparing Building Energy Performance and Greenhouse Gas Emissions
- 5.10.3** ANSI/ASHRAE/IESNA Standard 90.1-2016, Energy Standard for Buildings Except Low-Rise Residential Buildings
- 5.10.4** International Code Council, 2018 International Energy Conservation Code, ICC